

**Reading:** OpenStax, Chapter 24, all sections

**EXAM #2:** Wednesday, October 21 in recitation (just like Exam 1). Review materials (topic lists and sample questions) are now available (bottom of Modules).

---

## Previously: **Black Holes I: Formation and environment**

- Gamma ray bursts (GRBs) — distant explosions of ENORMOUS energy
- Hypernova (long GRB) — massive stars produce cores that are too massive for neutron degeneracy pressure
- Black holes — why they are black: escape velocity  $>$  speed of light
- Types of black holes and how we know they exist

## Today: **Black Holes II: Relativity and the weird nature of black holes**

- General relativity: mass distorts space-time and distortion acts as gravity
- Black holes are effectively “holes” in space-time — nothing can escape!
- Material falling into black holes gets tidally disrupted and never actually crosses the event horizon (from our perspective)
- Gravitational waves are ripples in space-time that can tell us more about the Universe.

# Review: different types of black holes

Type	Mass ( $M_{\text{Sun}}$ )	Detected by obs/exp?
1. Stellar mass black holes	>3-10ish	Yes
2. Supermassive black holes (SMBHs)	$10^6$ - $10^9$	Yes
3. Intermediate mass black holes (IMBHs)	100-1000	Maybe?
4. Primordial black holes	Very uncertain, but can be as small as $10^{-37} M_{\text{Sun}}$ ( $10^{-5}$ grams)	No

# Black Holes

- Gravity is so immense that escape velocity exceeds the speed of light

## Escape velocity:



### How fast a rocket would have to go to leave every planet

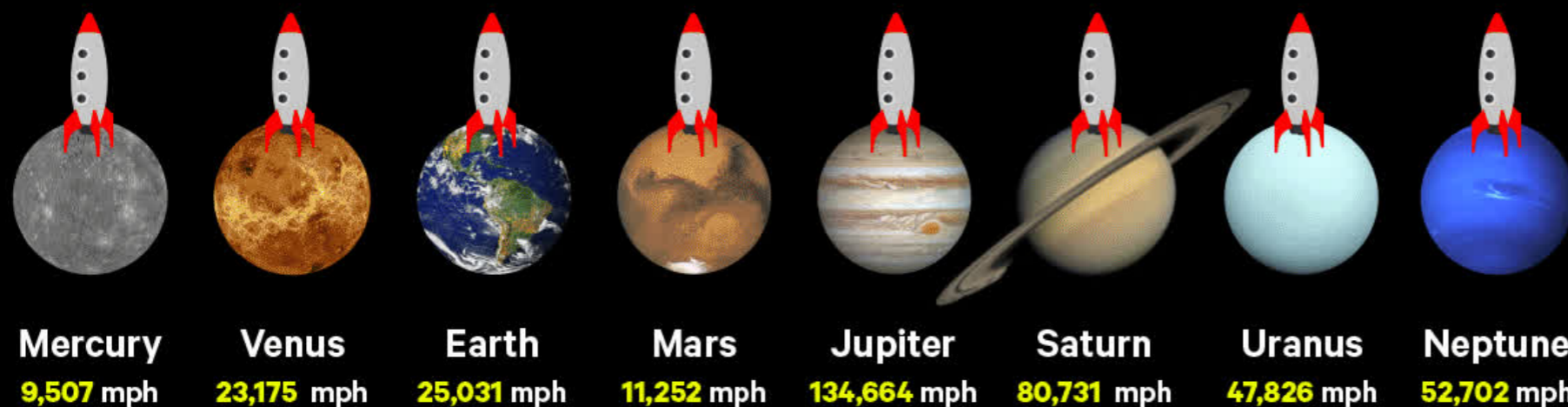

SOURCE: NASA

TECH INSIDER

# Escape velocity is not just about mass

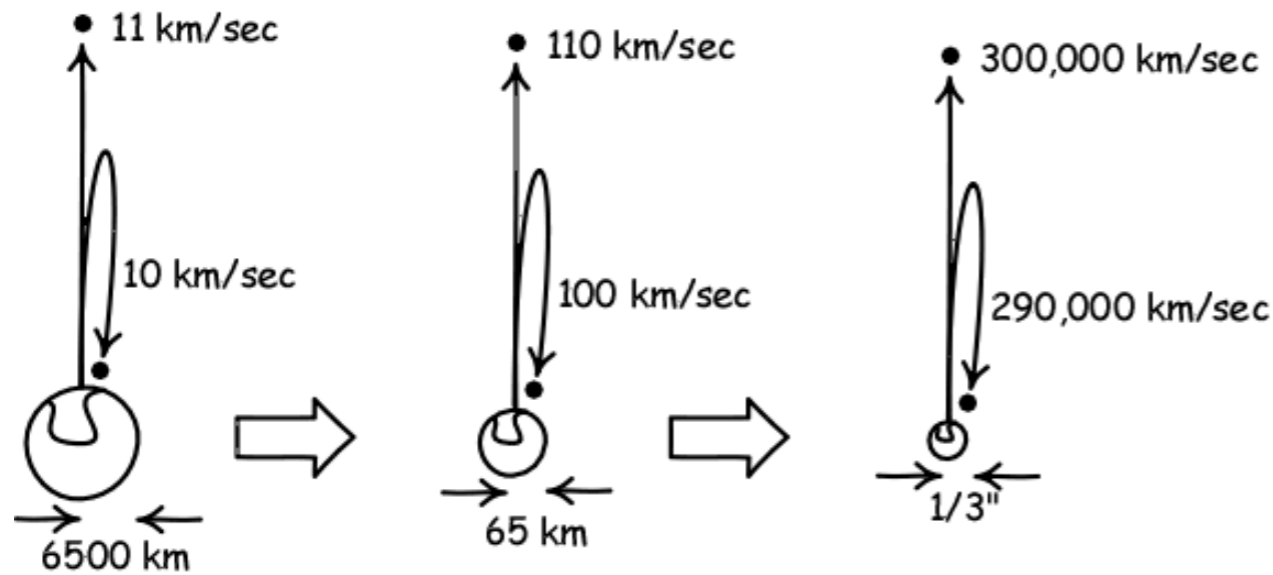

Inverse square law!

$$F = \frac{GMm}{r^2} \propto \frac{1}{r^2}$$

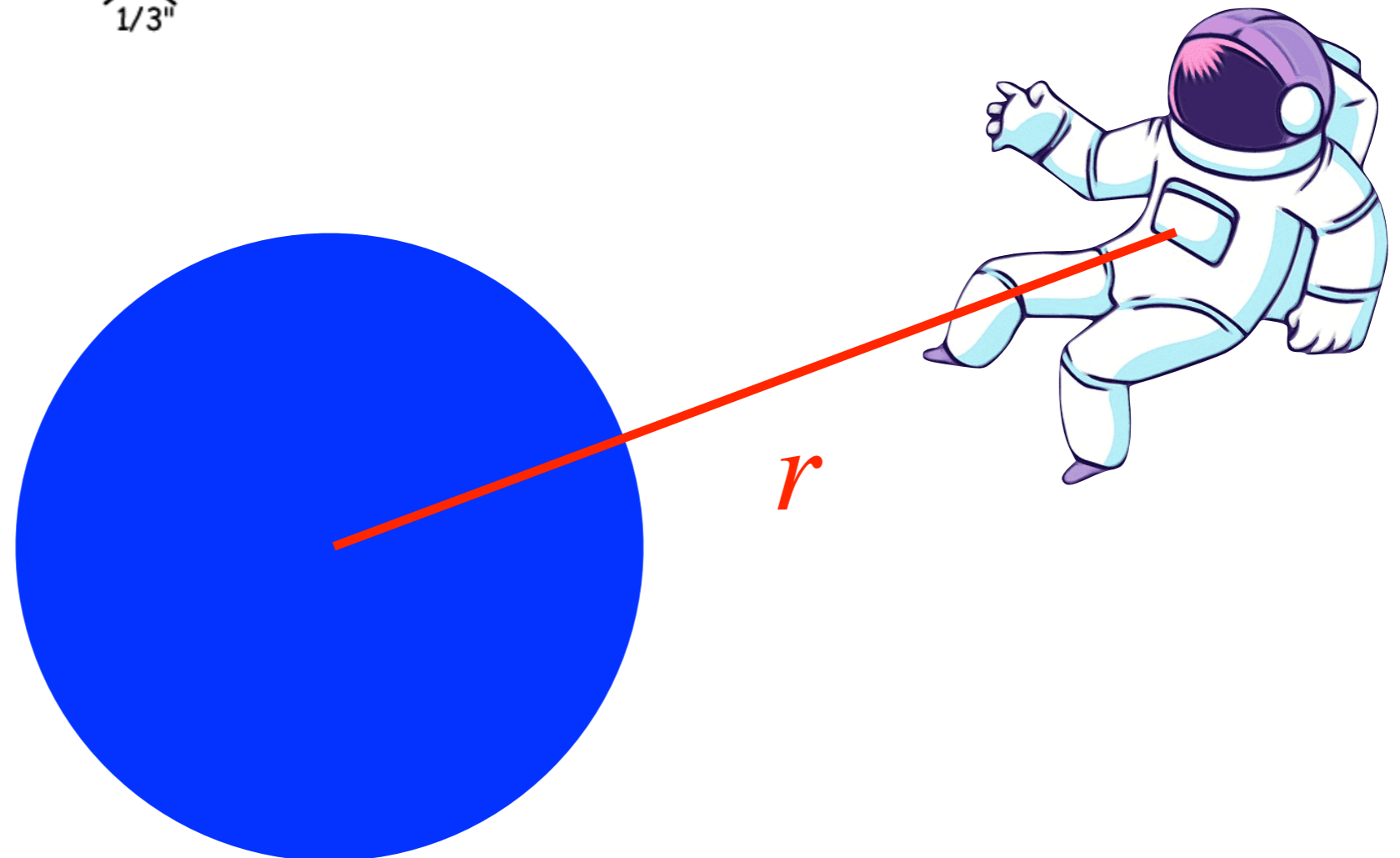

# Escape velocity is not just about mass

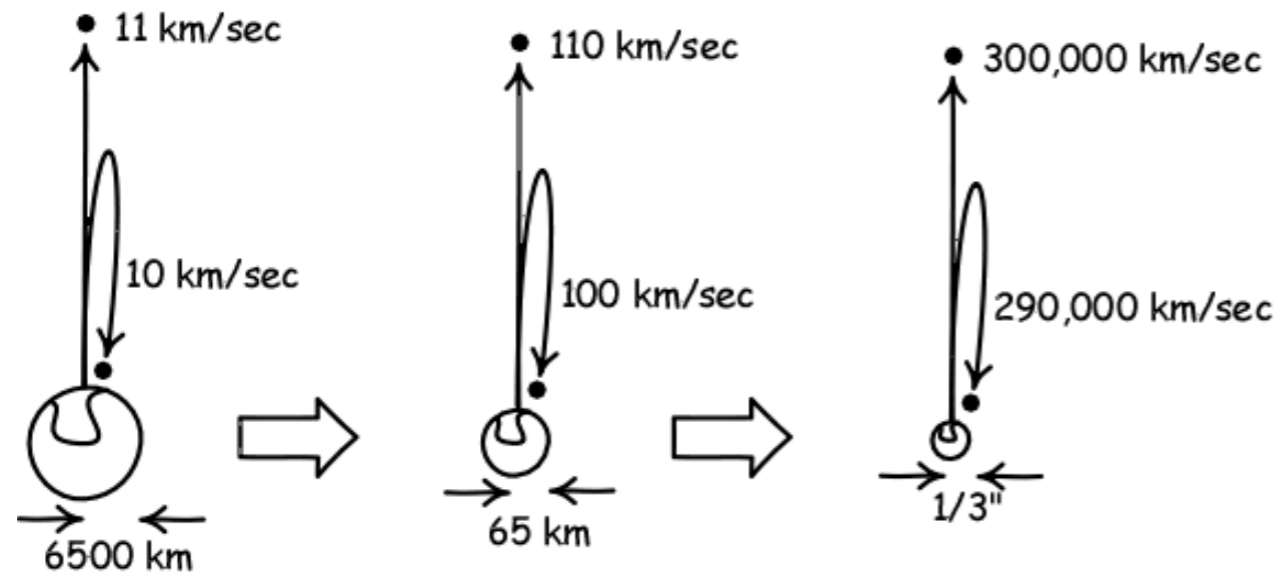

Inverse square law!

$$F = \frac{GMm}{r^2} \propto \frac{1}{r^2}$$

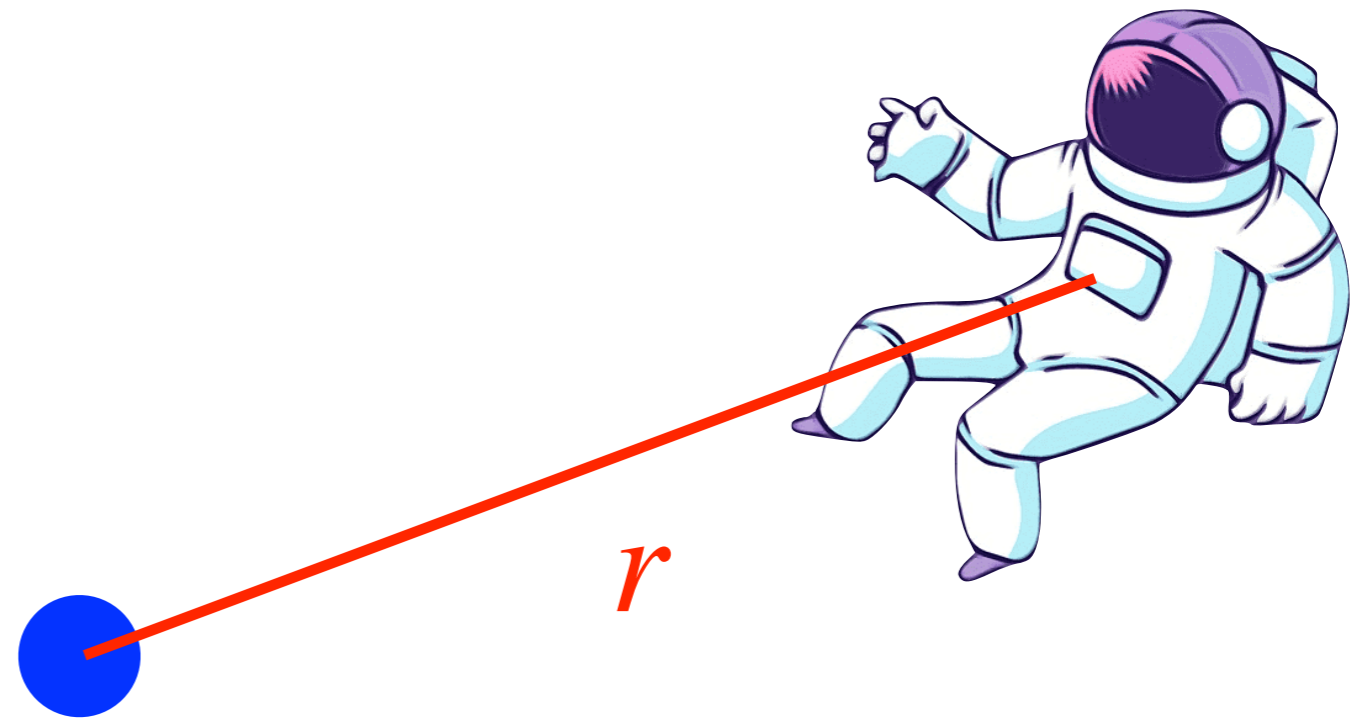

# Escape velocity is not just about mass

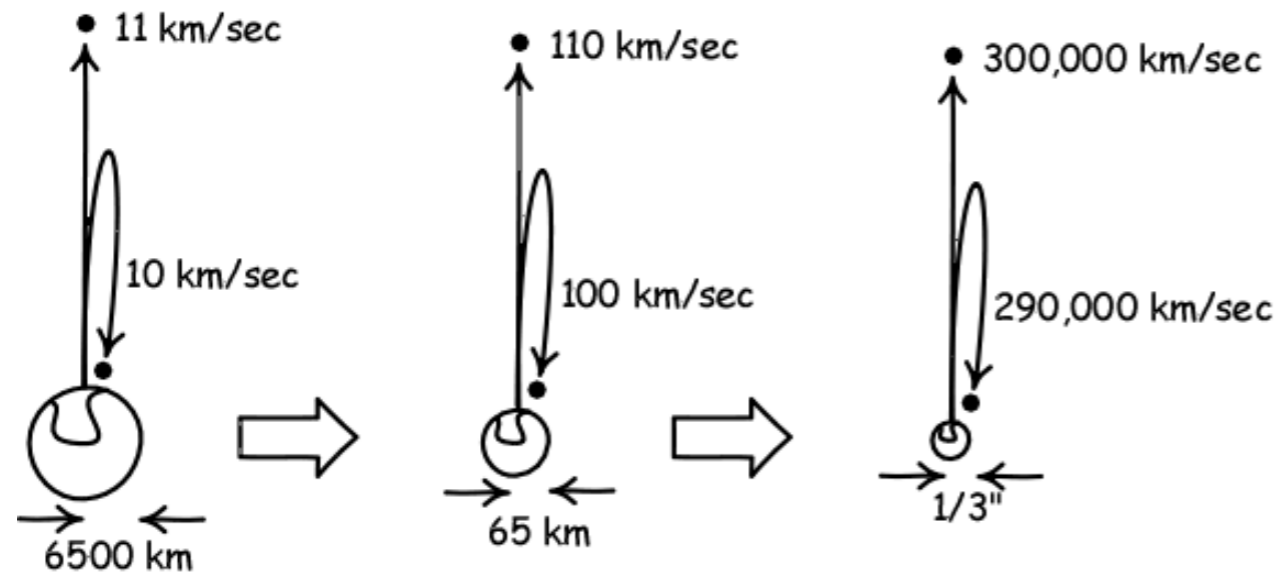

Inverse square law!

$$F = \frac{GMm}{r^2} \propto \frac{1}{r^2}$$

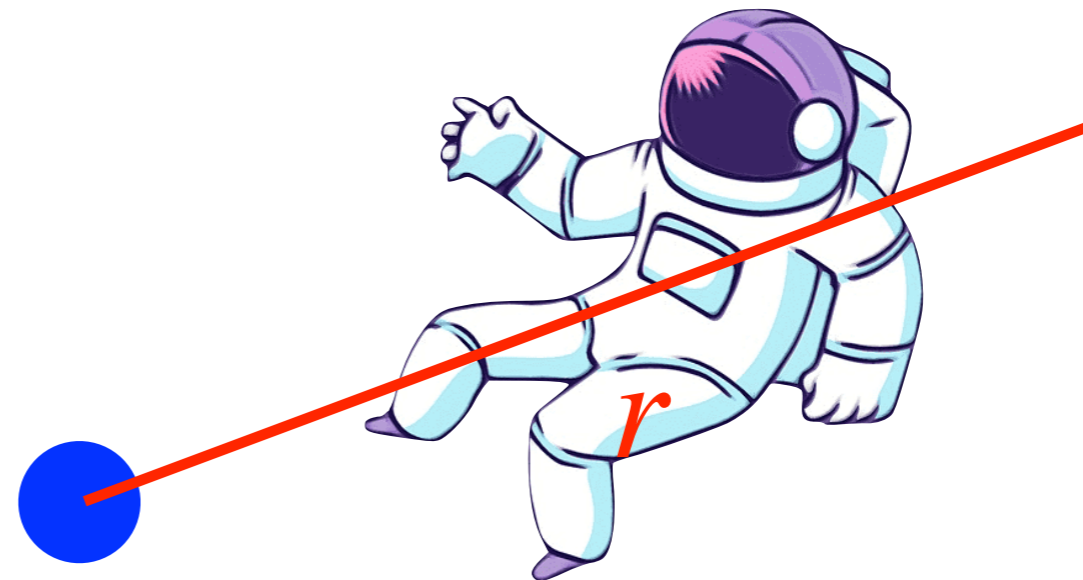

# Escape velocity is not just about mass

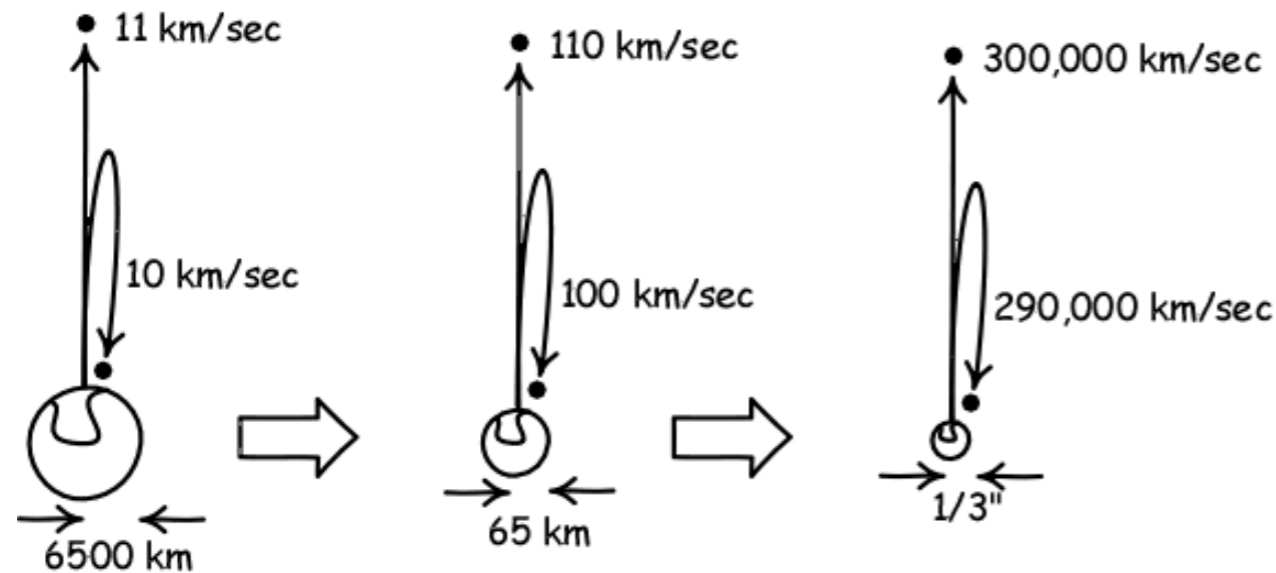

Inverse square law!

$$F = \frac{GMm}{r^2} \propto \frac{1}{r^2}$$

*Astronaut is now closer.  
r decreases but M stays the  
same!*

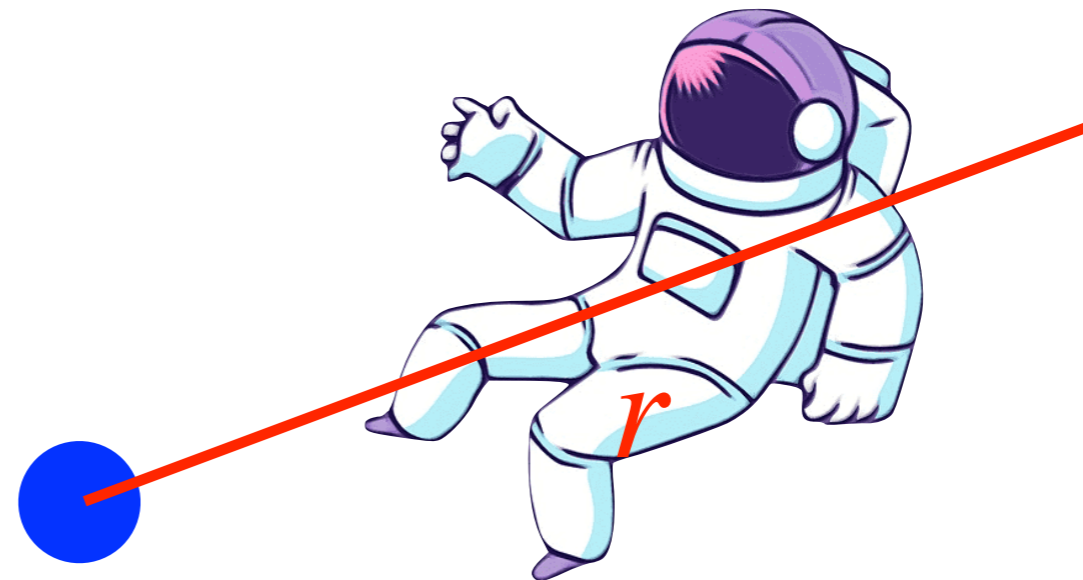

# Brief aside: Black holes do not suck

$$F = \frac{GMm}{r^2}$$

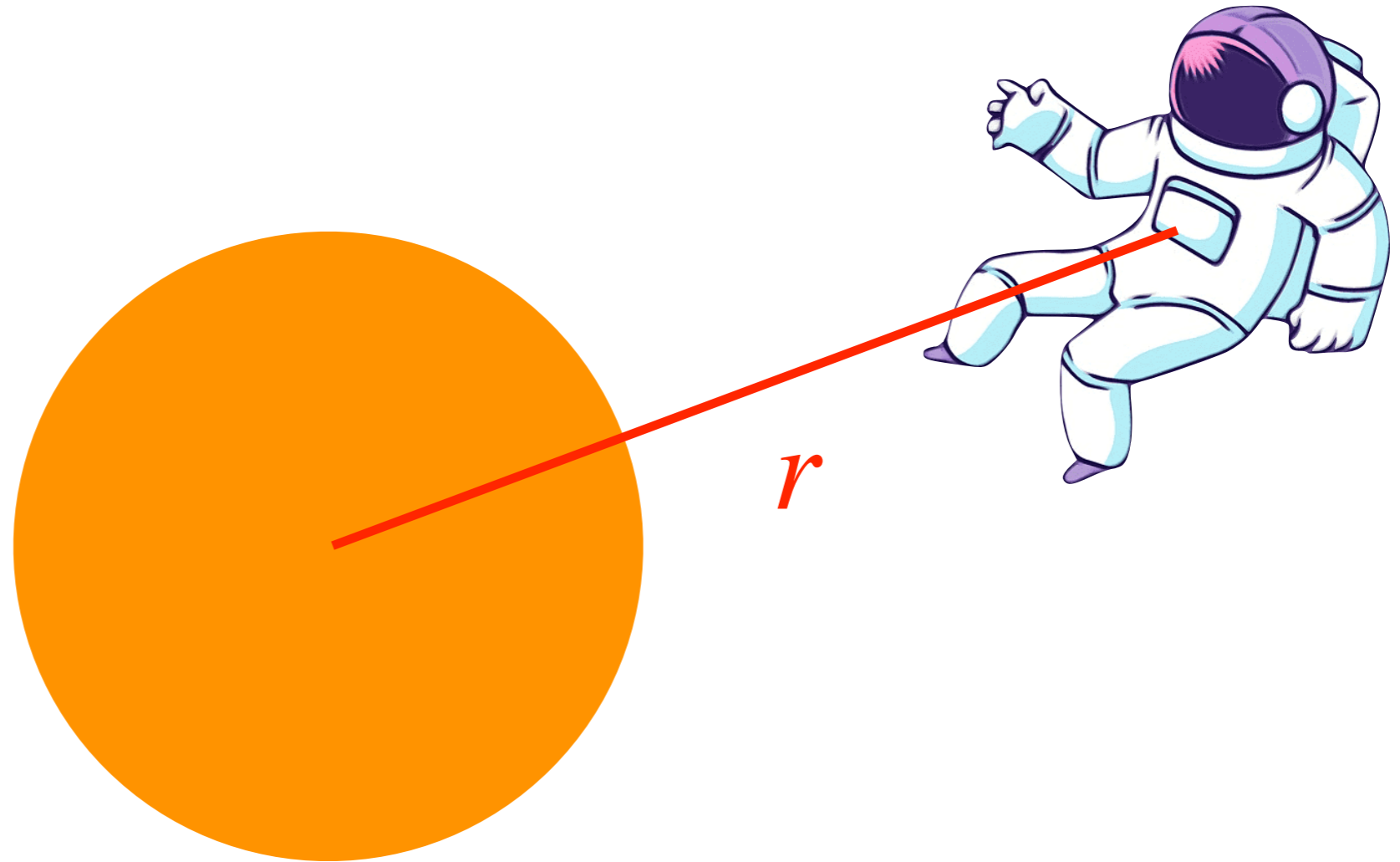

- Force of gravity remains the same if object turns into a black hole!
- So, if the Sun became a black hole, Earth would still orbit it just as it has been (though it would get a LOT colder!)



# Brief aside: Black holes do not suck

$$F = \frac{GMm}{r^2}$$

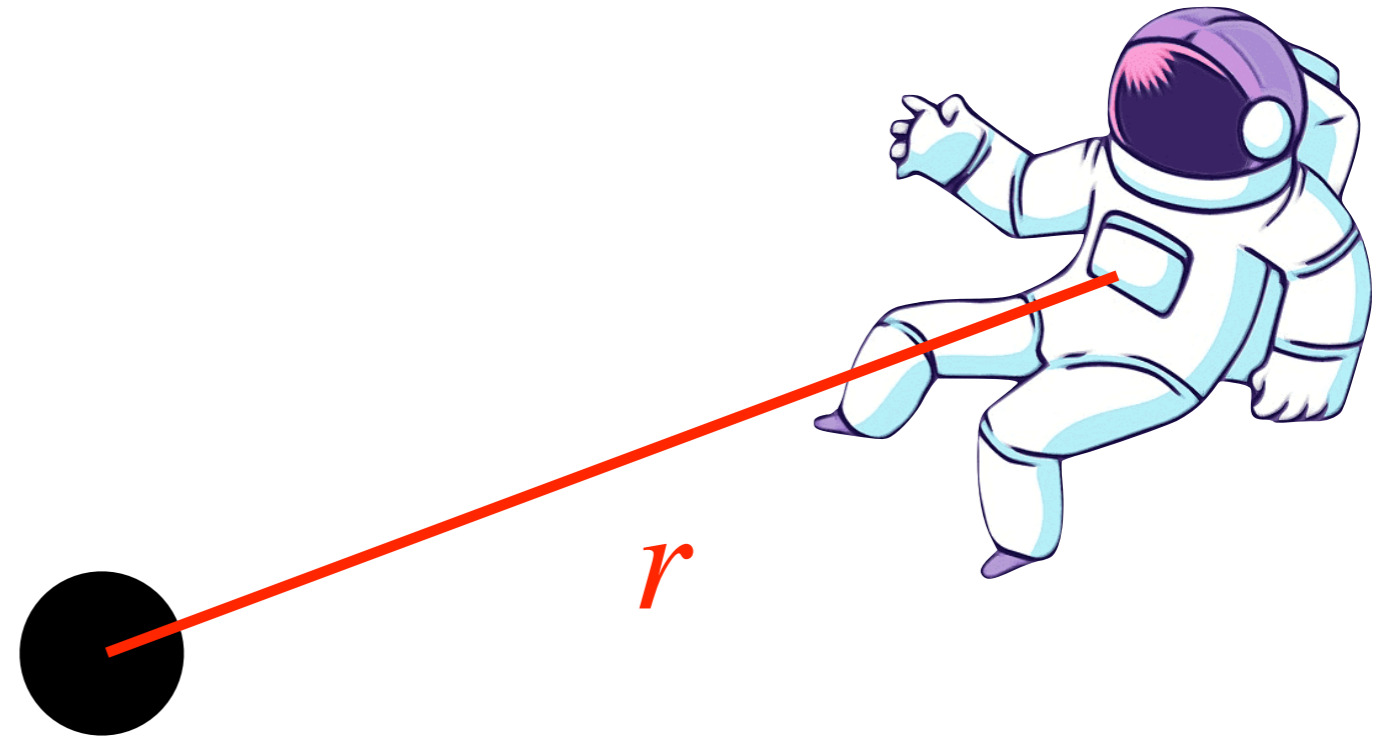

- Force of gravity remains the same if object turns into a black hole!
- So, if the Sun became a black hole, Earth would still orbit it just as it has been (though it would get a LOT colder!)

# Black holes and escape velocity

## • Escape velocity

- from **Earth** = 11.3 km/s (= 25,000 mph)
- from **Sun** = 600 km/s (= 1,350,000 mph)
- from a **WD** = 5000 km/s
- from a **NS** = 200,000 km/s = **2/3 the speed of light!**
- from a BH = 300,000 km/s = speed of light!

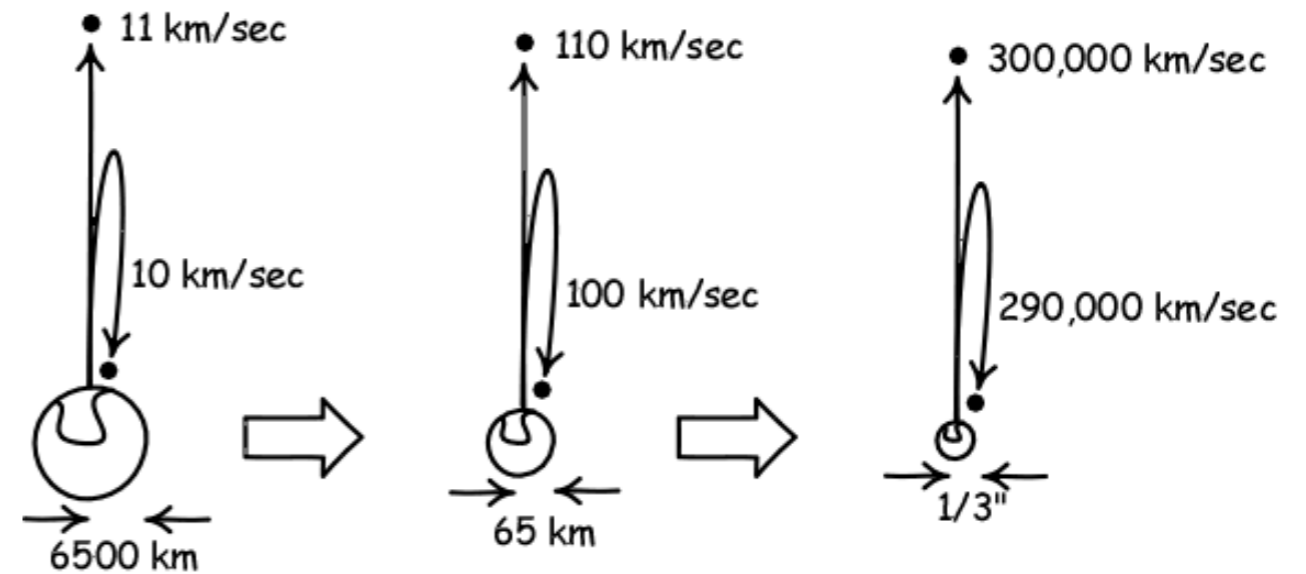

# But how can light “fall” back down if photons don’t have mass???

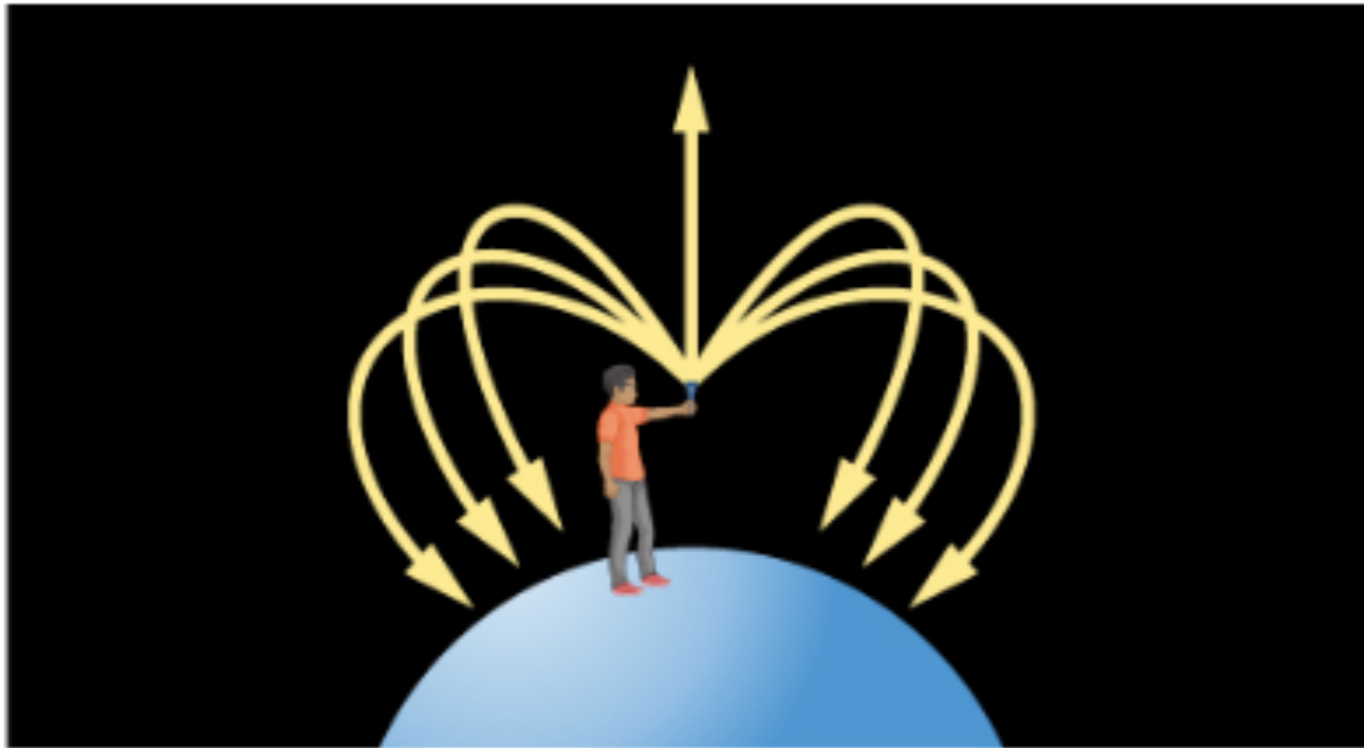

$$F = \frac{GMm}{r^2}$$

*Need to re-think gravity!*

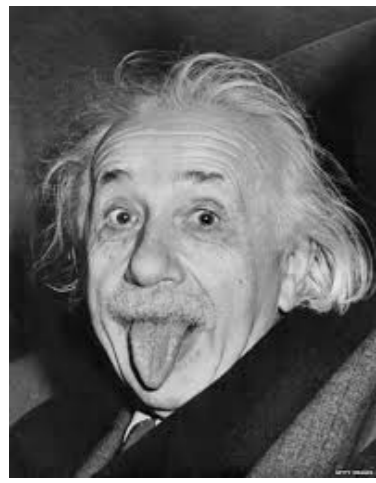

*Albert Einstein*

# Principle of Equivalence

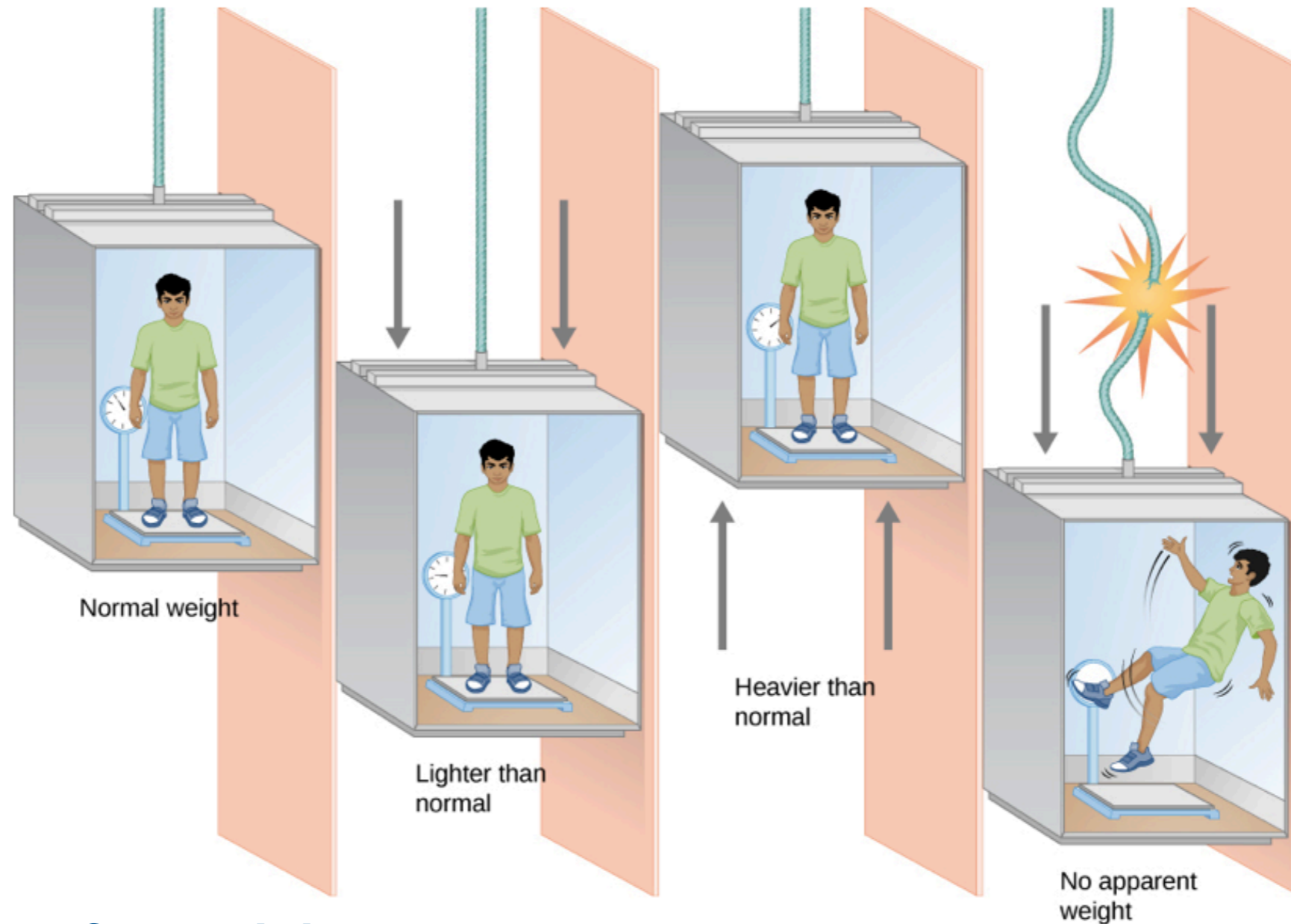

- In free fall, you feel weightless
- Would not be able to tell the difference between a free-falling elevator and one that is simply moving through space

# Principle of Equivalence

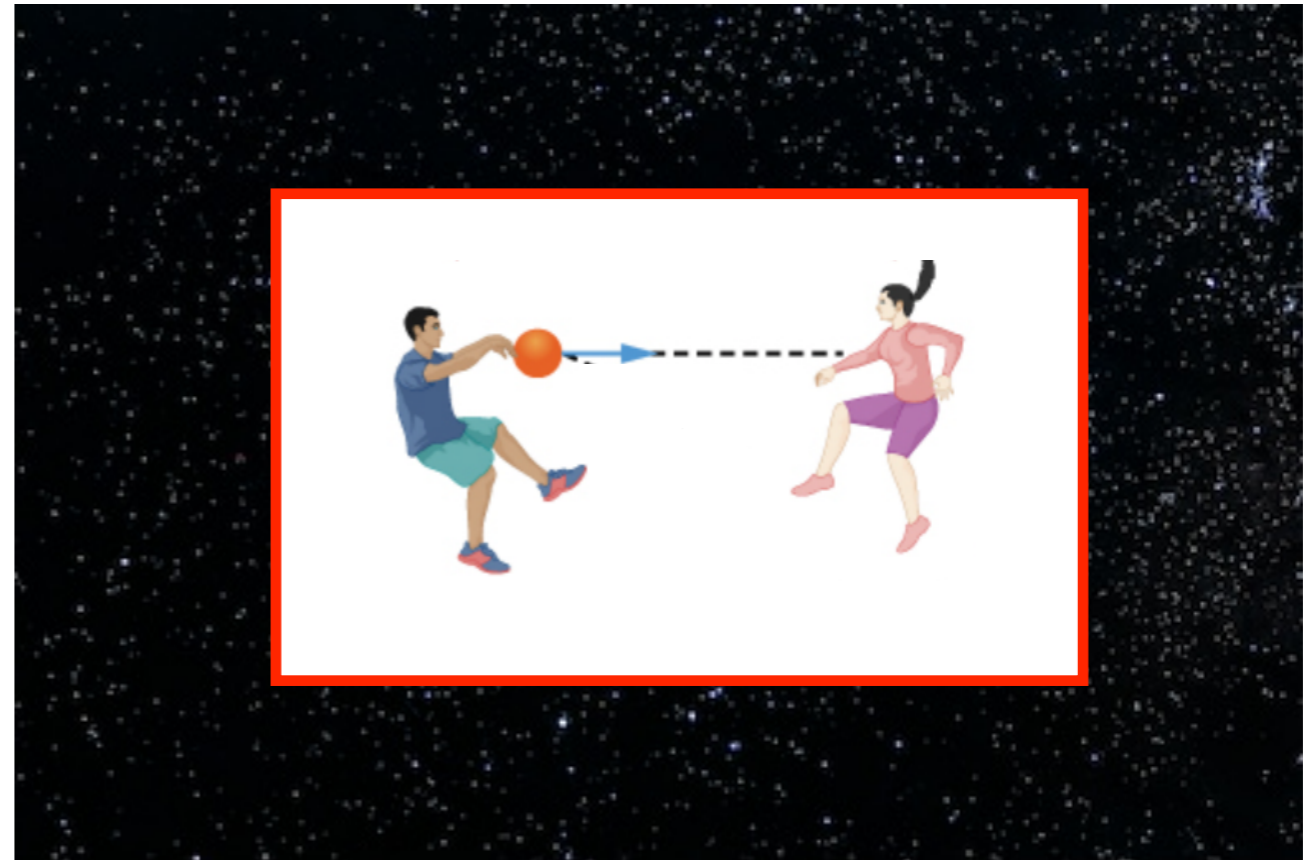
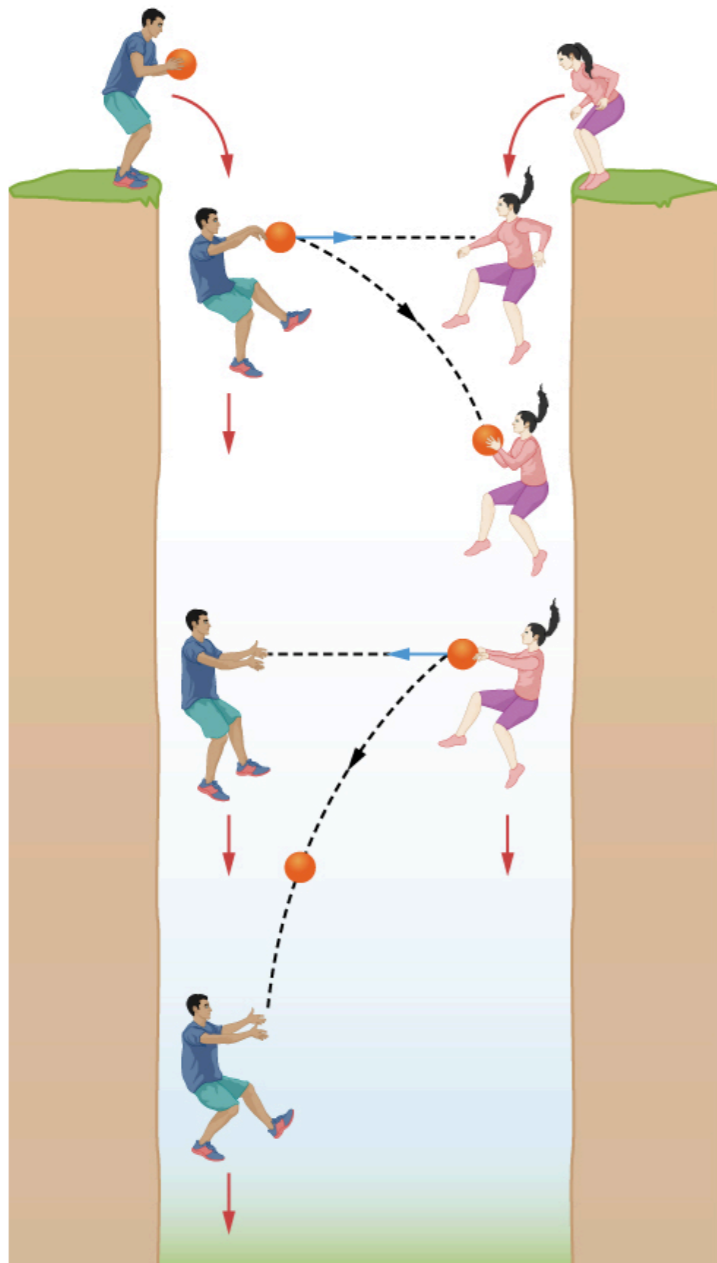

- From the perspective of the falling people, playing catch while falling is the same as playing catch in outer space

# Principle of Equivalence

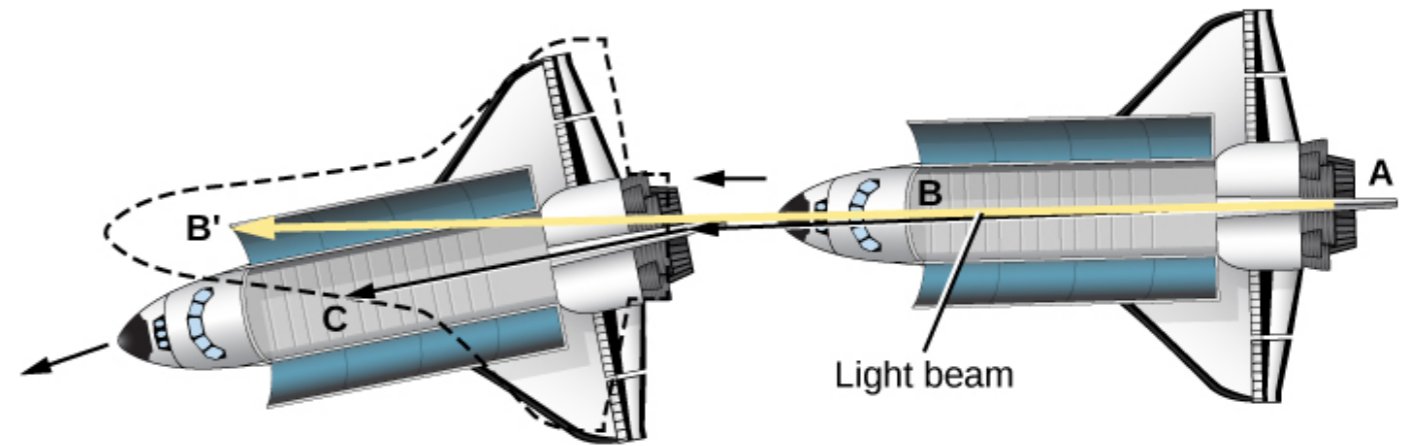

- Astronauts on a space shuttle or the space station feel weightless because they are actually (perpetually) in free-fall towards the Earth
- They of course never actually crash into the Earth because they have the right velocity to orbit around it!
- If instead of playing catch with fruit or a basketball, they shined a light from one end of the shuttle to another, they would see the light hit the exact opposite wall

# For this to happen, light must “curve”

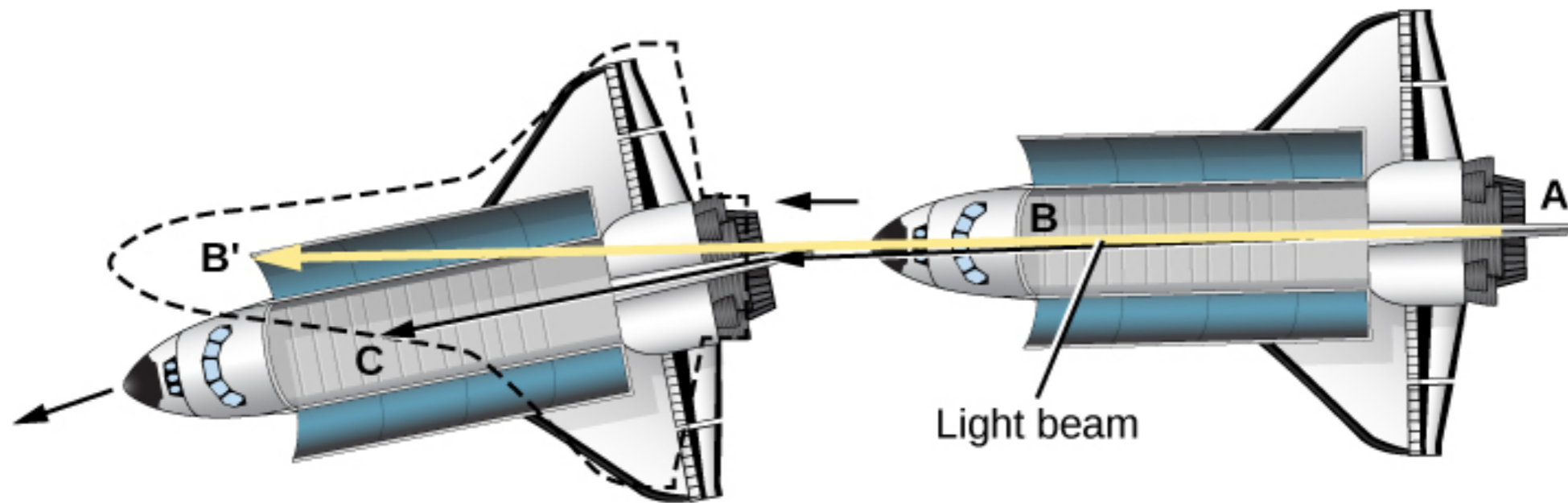

# General relativity: gravity is the curvature of space(-time)!





# Brief pause: What is space-time??

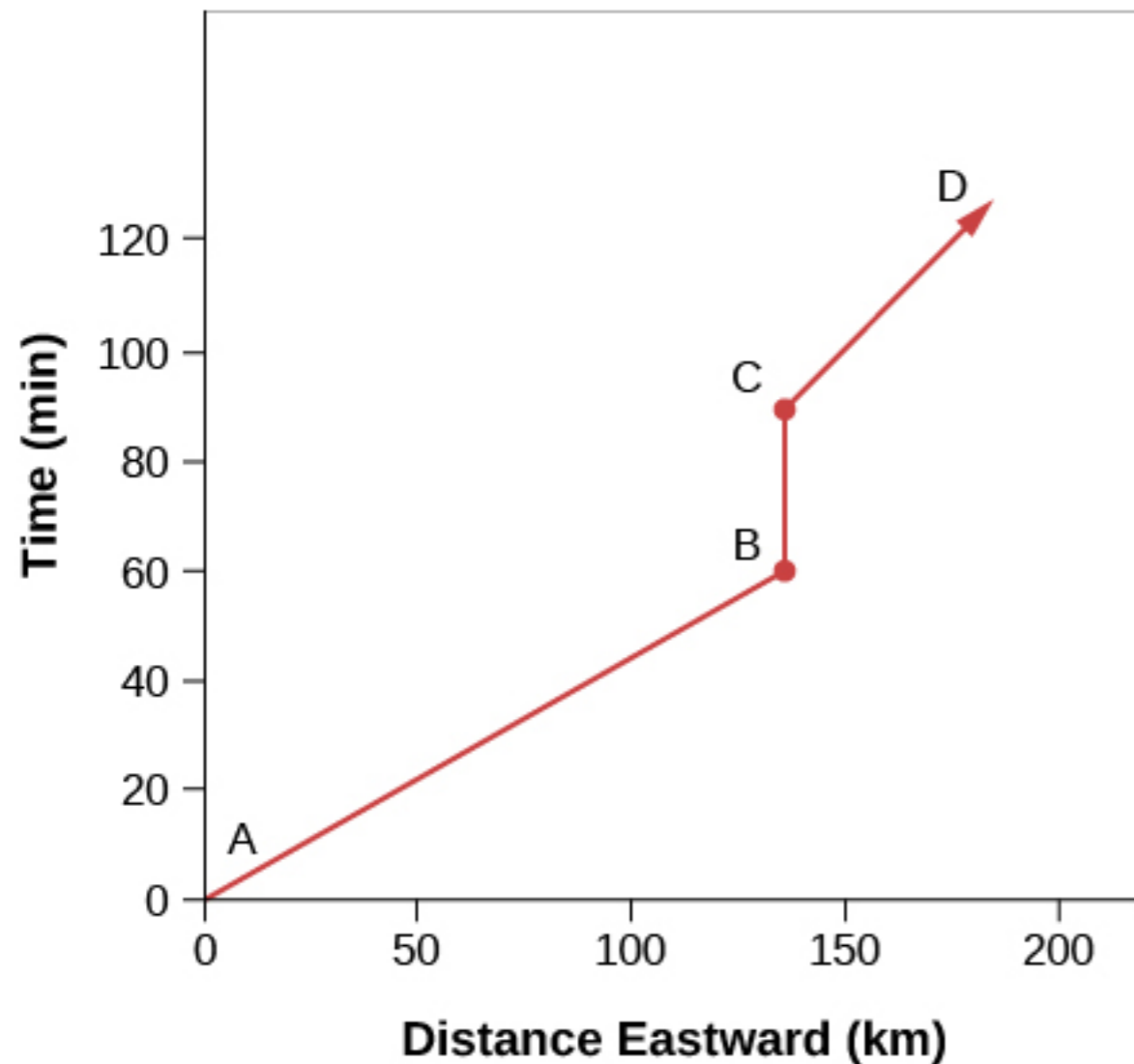

- To really say where something **IS**, you have to specify a location in space **AND** time
- Einstein showed that space and time are intimately connected into a sort of fabric of the Universe: “space-time”
- This leads to some very strange behaviors when it comes to black holes

# Mass bends space-time and this space-time curvature tells mass (and light) how to move!

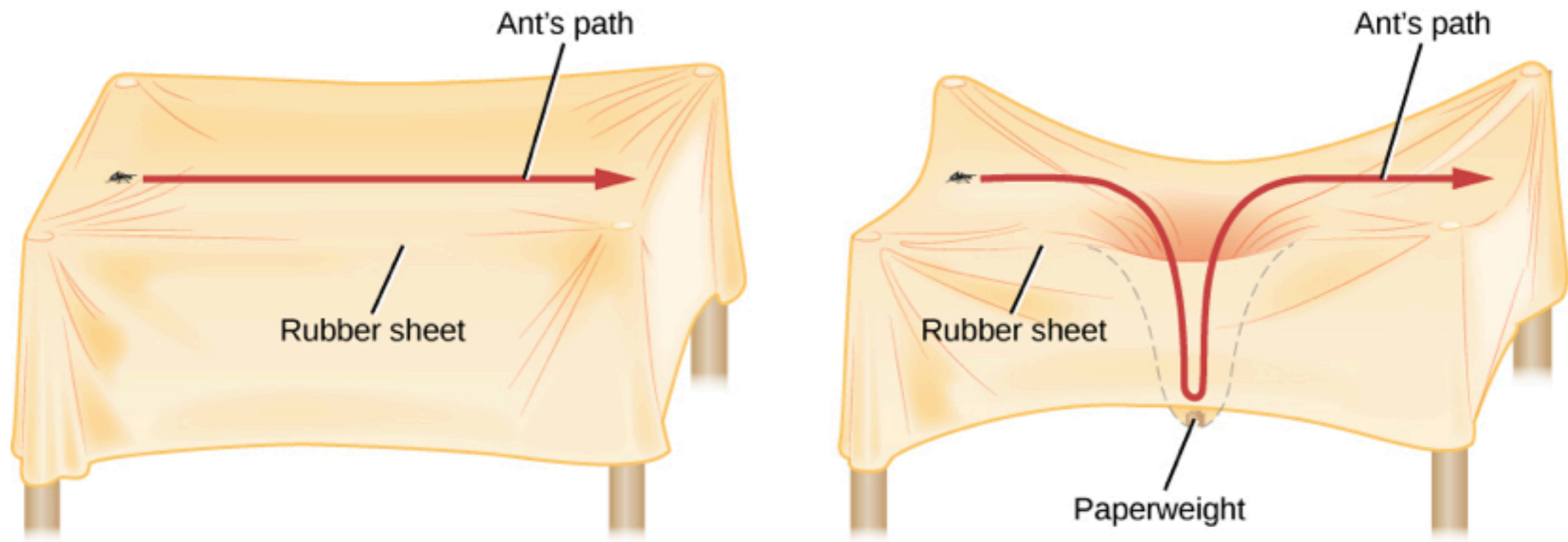

# Tests of GR

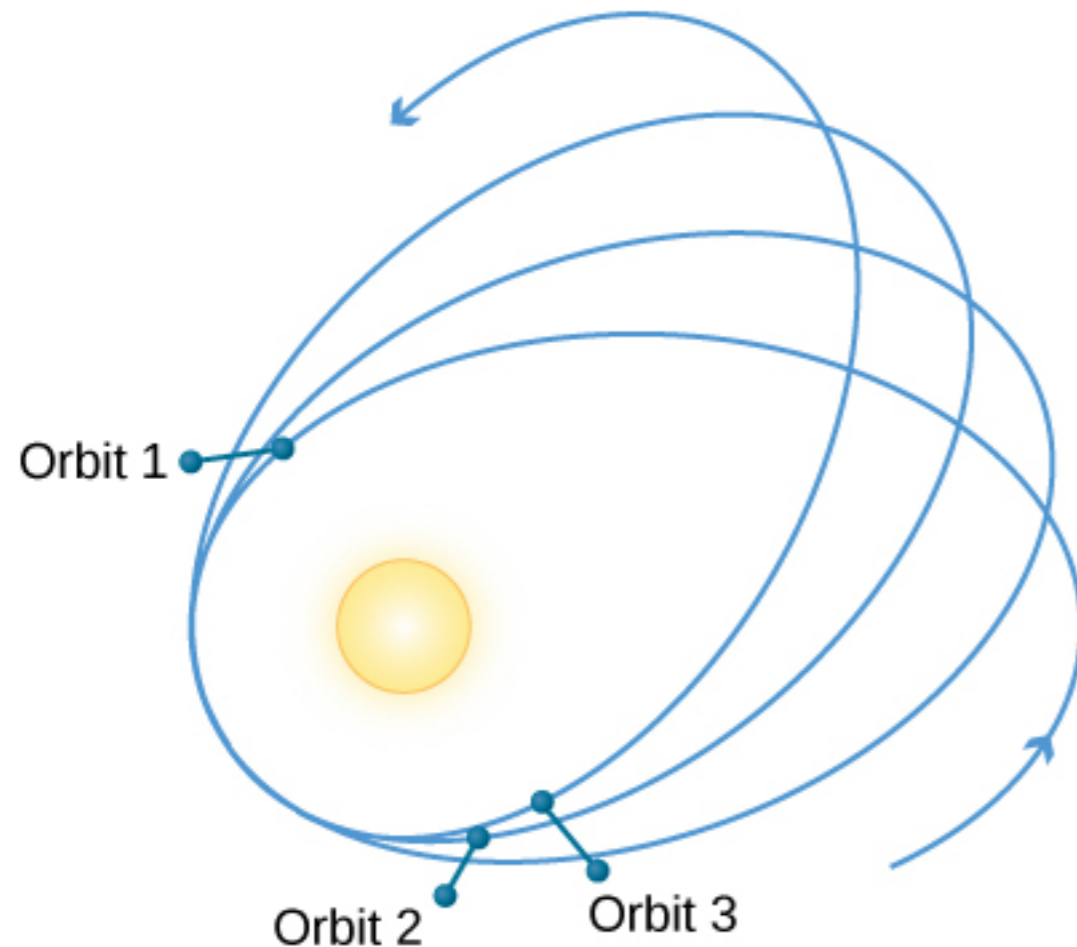

- Mercury's orbit was known to “wobble”
- Previously thought that there was another planet closer to the Sun (Vulcan!)
- But when GR came along, it could explain the wobble

**This is an example of a “post-diction”**

# Tests of GR

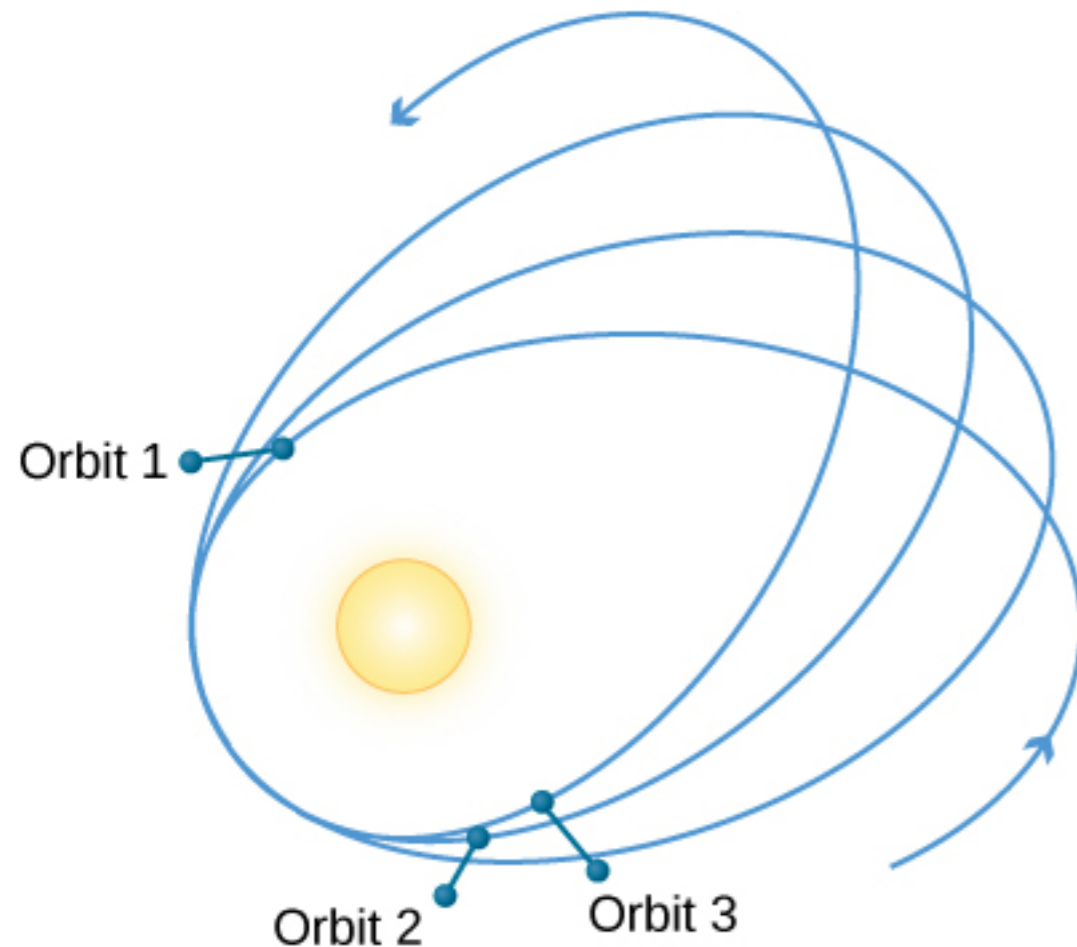

- Mercury's orbit was known to “wobble”
- Previously thought that there was another planet closer to the Sun (Vulcan!) 
- But when GR came along, it could explain the wobble

**This is an example of a “post-diction”**

# Tests of GR: an actual *prediction*



- Einstein predicted that the position of the stars would change when passing near the Sun
- Arthur Eddington tested this with two expeditions (West Africa, Brazil) to observe the effect during an eclipse
- Shifts were consistent with GR — win for Einstein and science!

# Black holes bend space-time to an extreme — they make a hole in the fabric of the Universe!

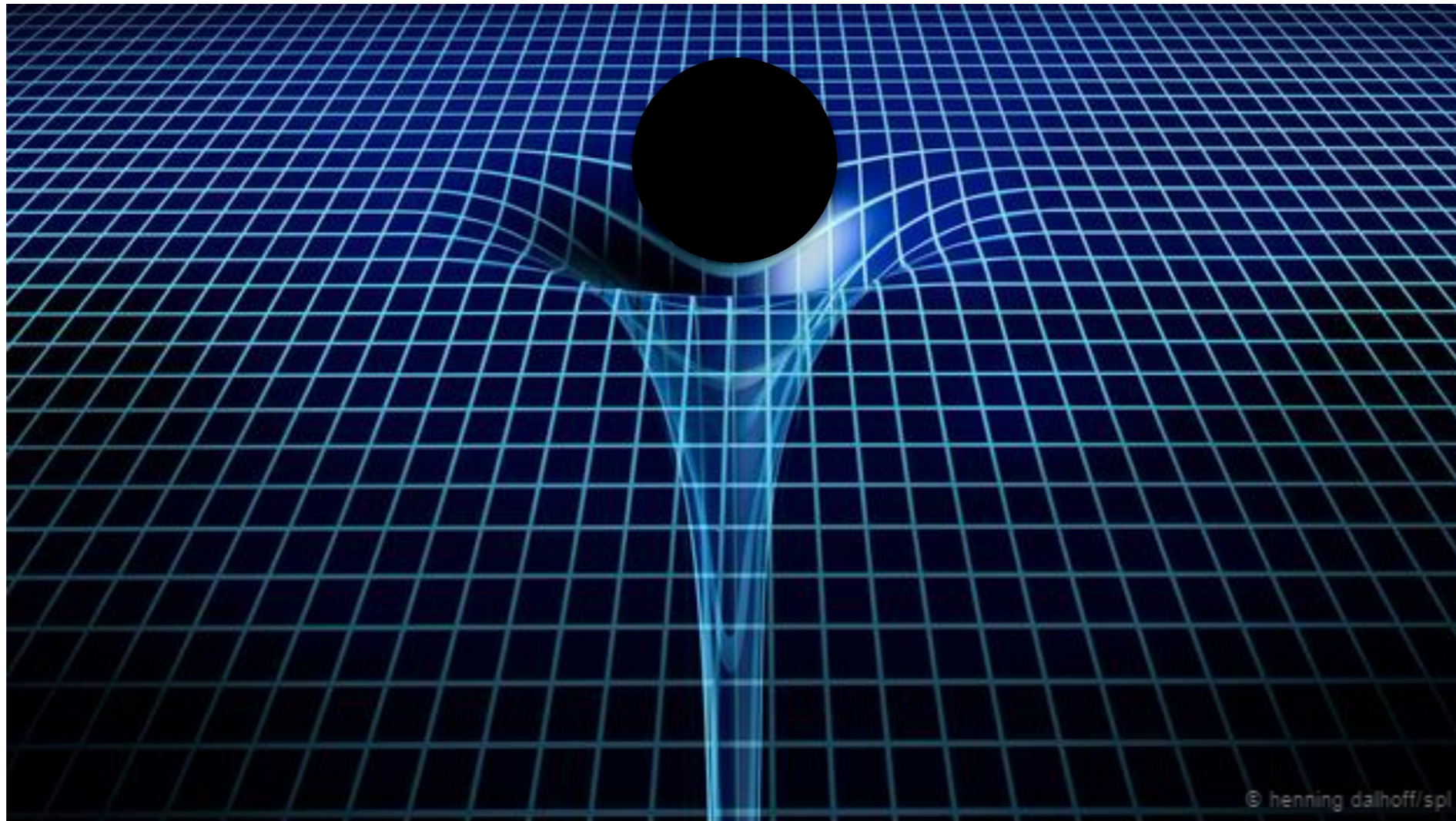

# Black holes truly represent a removal of whatever falls in from the Universe!

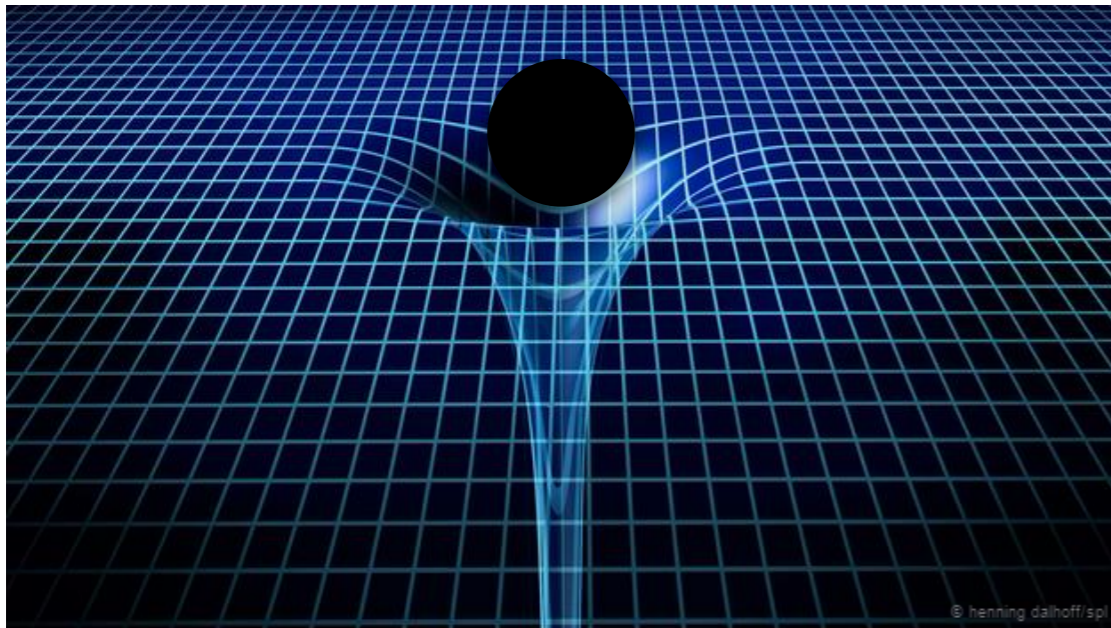

- **Because the curvature of space-time is so extreme that the fastest possible thing (light) can't escape, black holes do in fact represent a "hole" in space-time. You fall in and can't get out!**
- **Event horizon is like the edge of the hole**

**Now, let's look at what happens as an  
(unfortunate) astronaut falls into a  
black hole**



# This extreme curvature leads to **INCREDIBLE** tidal forces

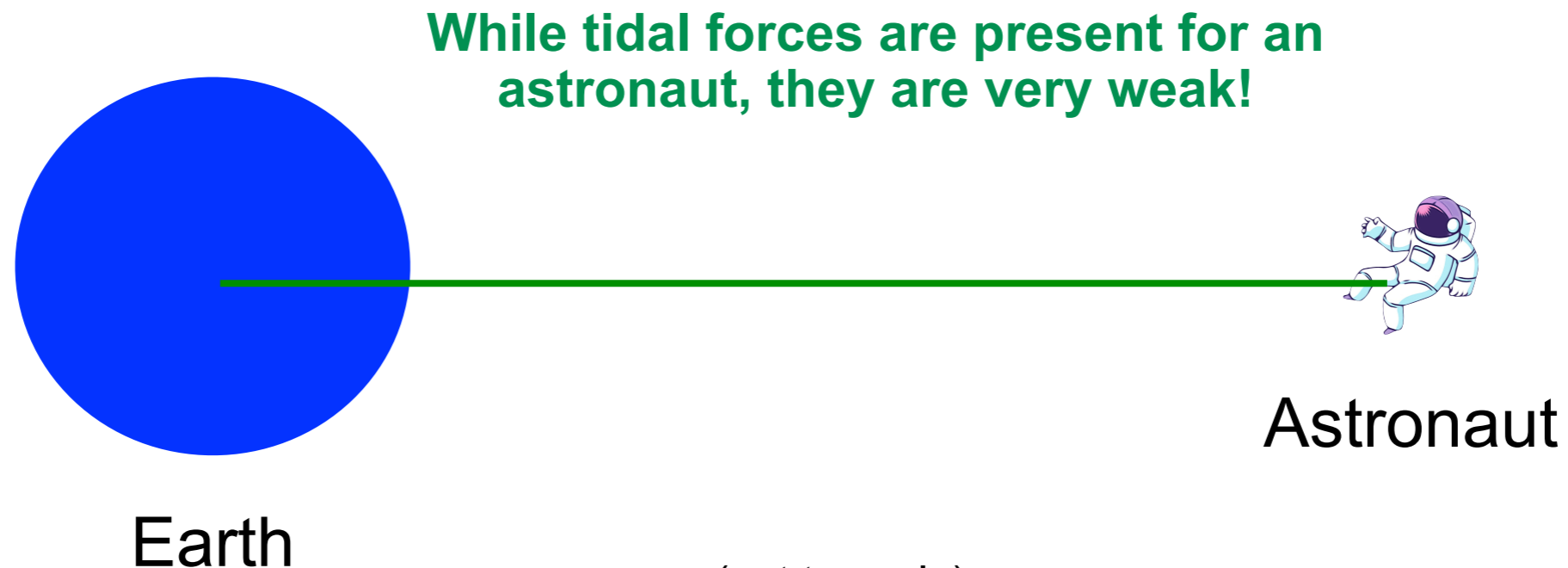

(not to scale)

# This extreme curvature leads to **INCREDIBLE** tidal forces

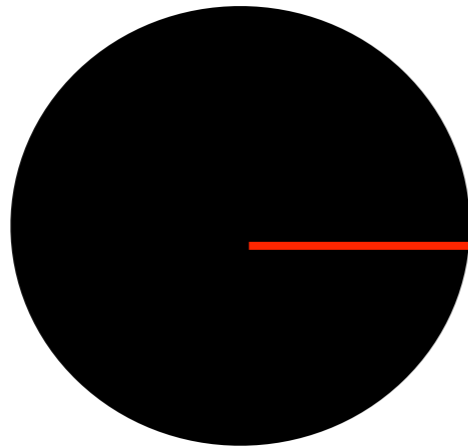

Black hole

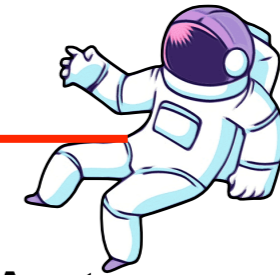

Astronaut

**But for a black hole, these  
tidal forces are EXTREME**

**Spaghettification!**

# This extreme curvature leads to **INCREDIBLE** tidal forces

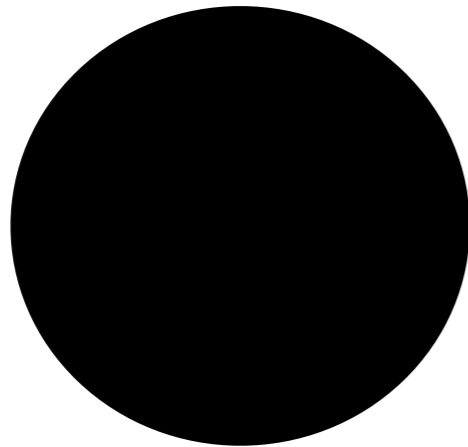

Black hole



Astronaut

**But for a black hole, these  
tidal forces are EXTREME**

**Spaghettification!**

# This extreme curvature leads to **INCREDIBLE** tidal forces

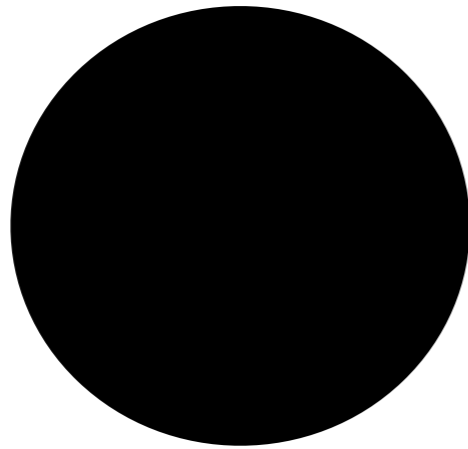

Black hole



Astronaut

**But for a black hole, these  
tidal forces are EXTREME**

**Spaghettification!**

# This extreme curvature leads to **INCREDIBLE** tidal forces

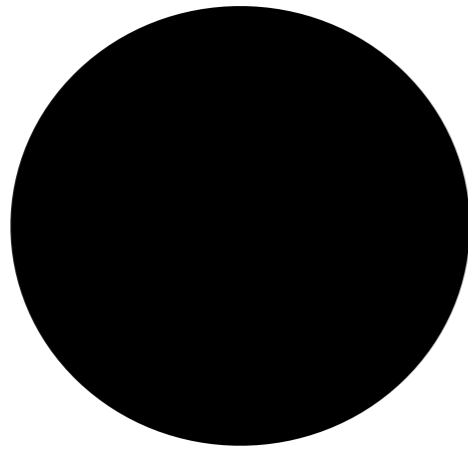

Black hole



Astronaut

**But for a black hole, these  
tidal forces are EXTREME**

**Spaghettification!**

# This extreme curvature leads to **INCREDIBLE** tidal forces

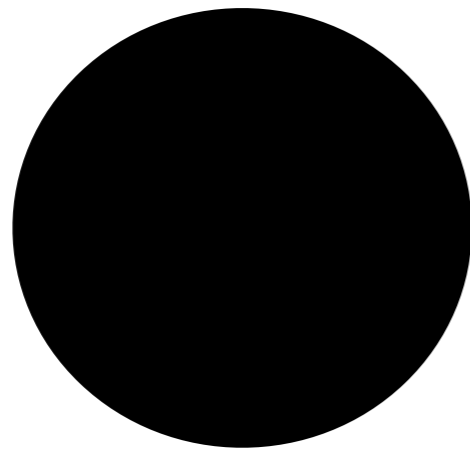

Black hole



Astronaut

**But for a black hole, these tidal forces are EXTREME**

**Spaghettification!**

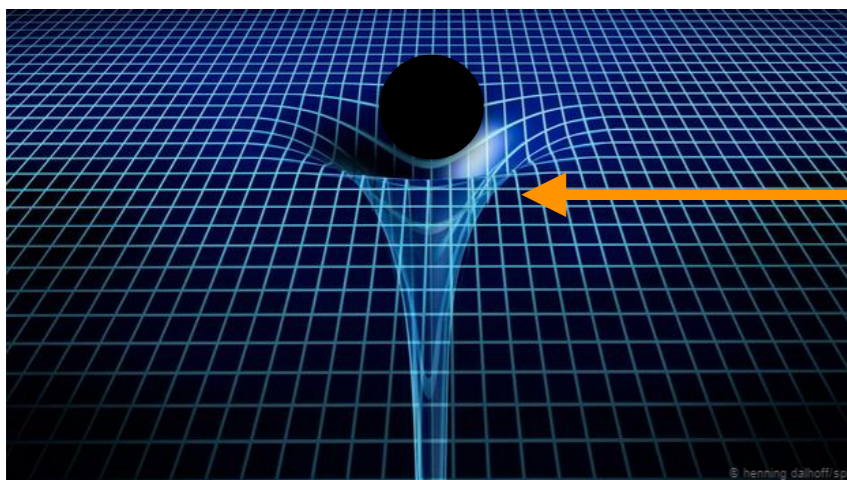

**This extreme stretching actually results from the extreme curvature of space-time around the black hole**

# Gravitational redshift

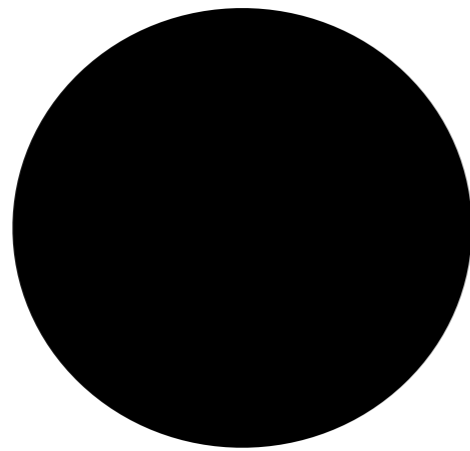

Black hole



Astronaut

Light itself gets stretched, leading to a *gravitational redshift*

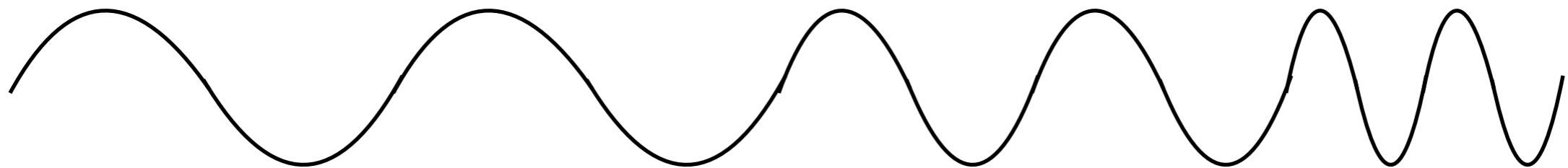

Longer wavelengths toward black hole

# Time dilation

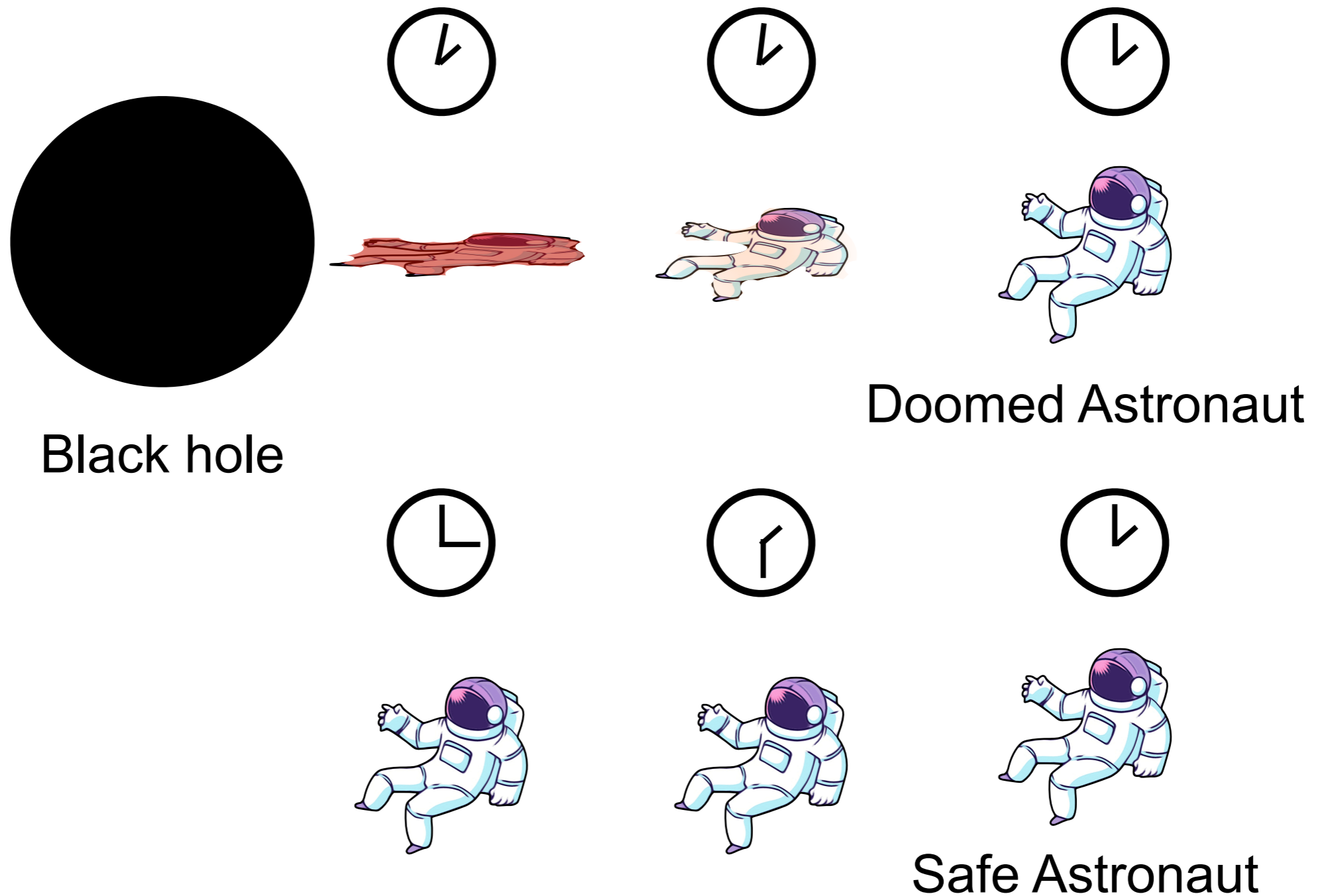

**Time itself slows down for the astronaut from our point of view**



# Time dilation

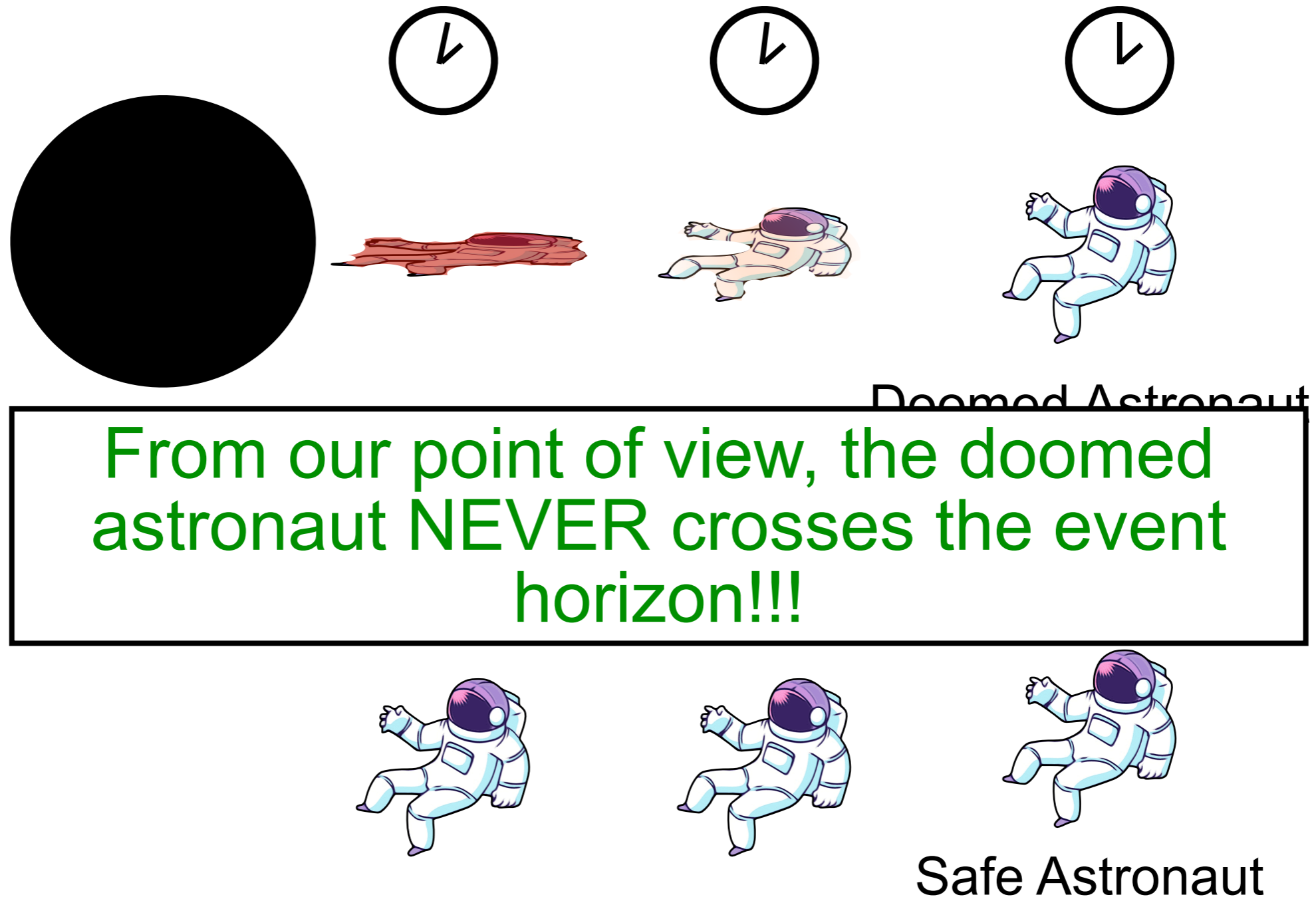

**Time itself slows down for the astronaut from our point of view**

# Time dilation happens on Earth too!

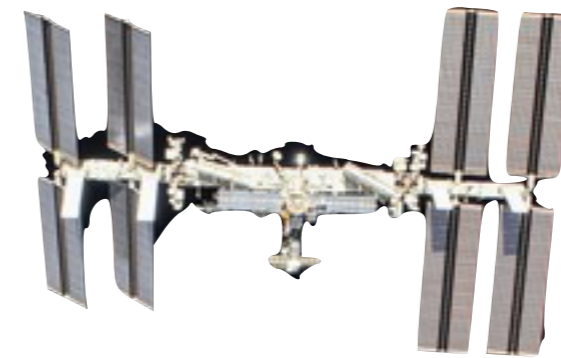

Clock on space station (or for satellites, etc.) tick 45 millionths of a second faster in space than on Earth

- Actually, this is counteracted by the rapid movement of the objects in orbit — special relativity says that time is slower for faster moving objects.
- Net effect: clocks in orbit are 38 microseconds per day faster than on Earth
- This can lead to navigational errors for GPS of ~7 miles over the course of one day!

# General (and special) relativity in your everyday life

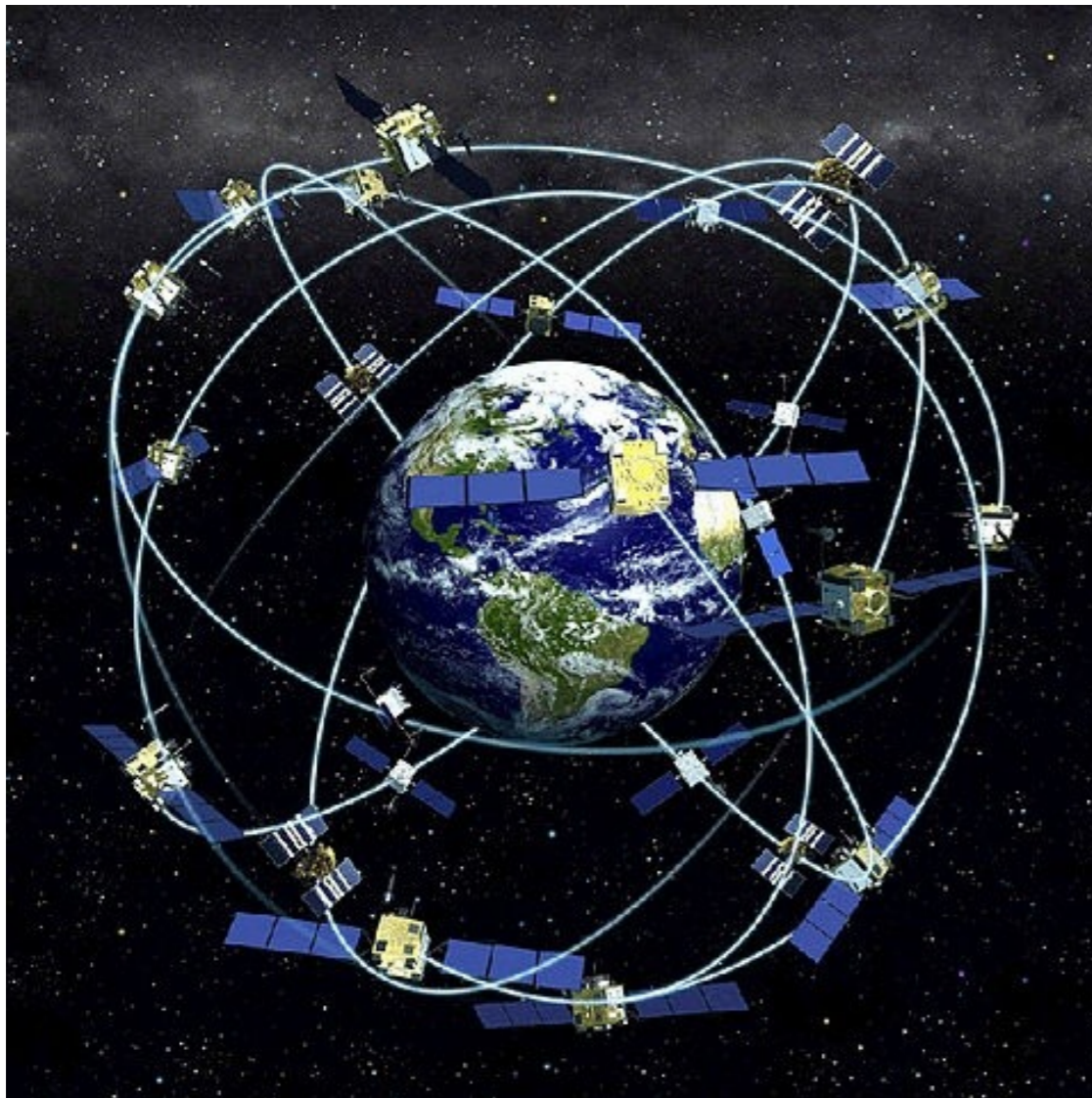

GPS systems have to account for relativity in order to provide accurate navigational information!

Next time the GPS gets you to your destination on time, thank Einstein!

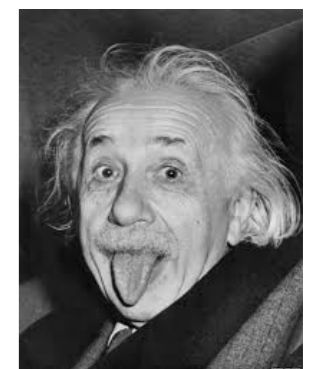

# Journey into a black hole contd.

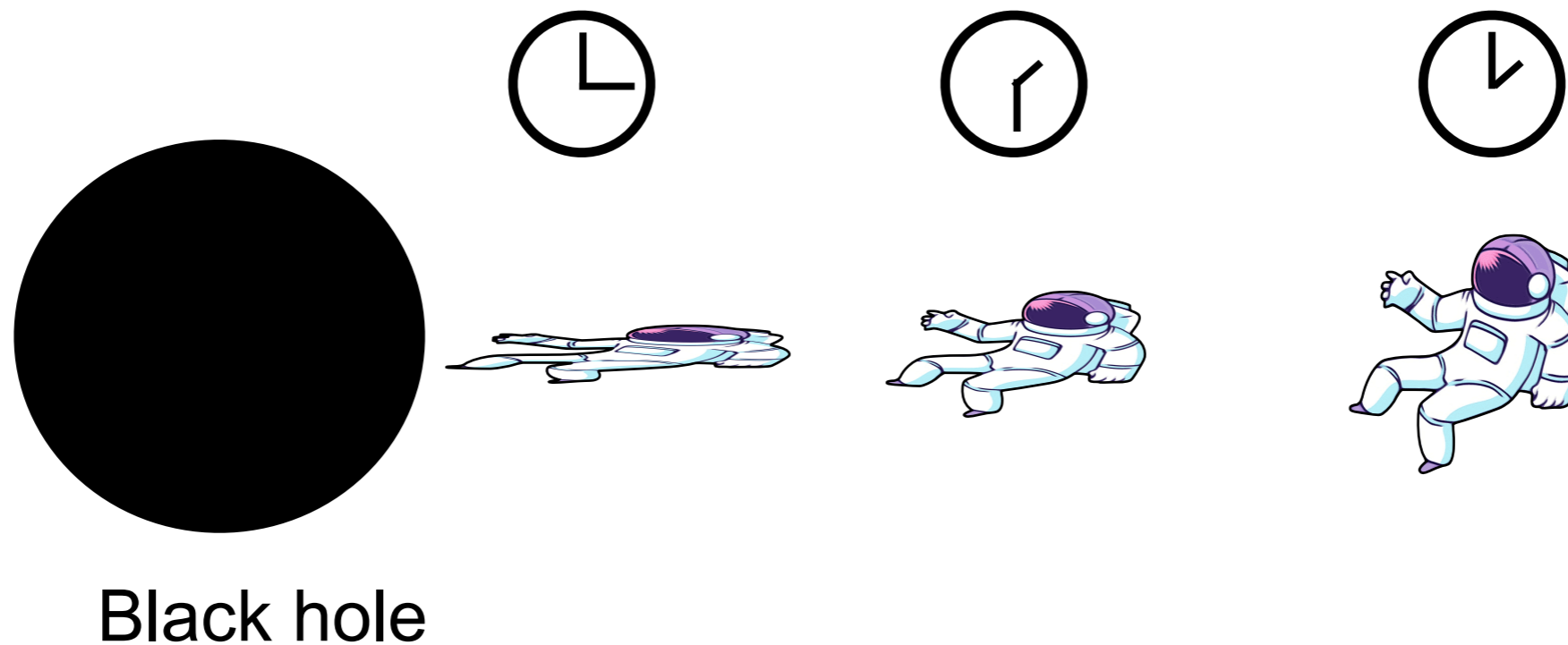

- Time moves normally for the astronaut
- Also, he/she doesn't appear redshifted
- Though, he/she may die from tidal forces!

# Journey into a black hole contd.

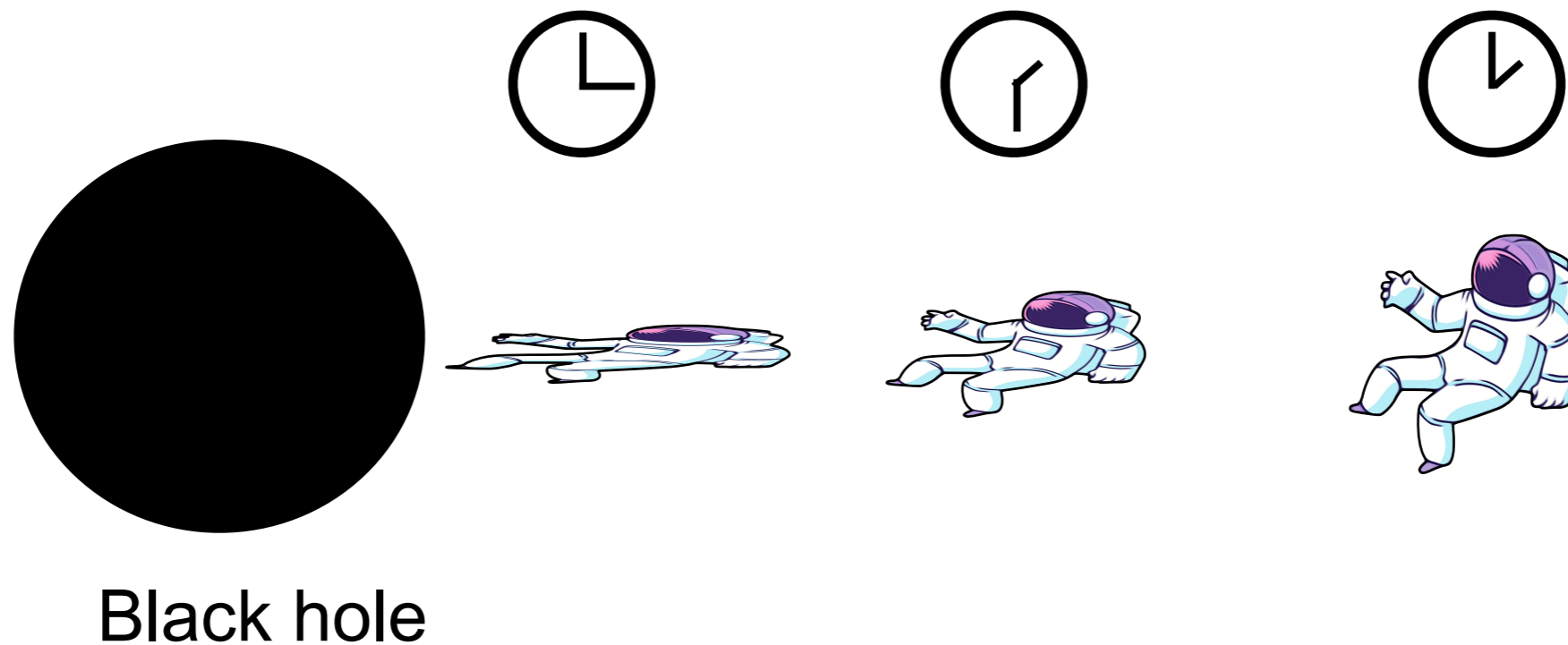

- Time moves normally for the astronaut
- Also, he/she doesn't appear redshifted
- Though, he/she may die from tidal forces!

*Let's for now assume he/she is falling into a supermassive black hole*

# Journey into a black hole contd.

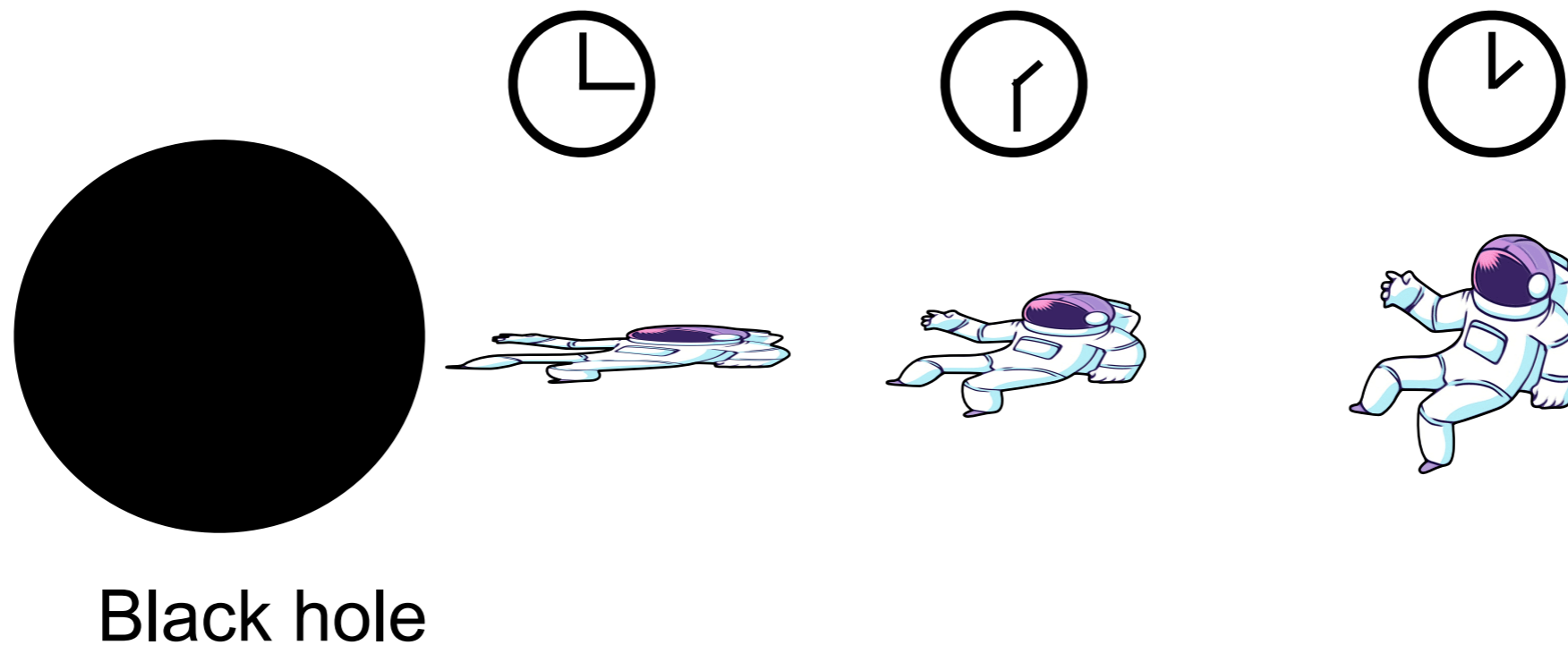

- Time moves normally for the astronaut
- Also, he/she doesn't appear redshifted
- Though, he/she may die from tidal forces!

*Let's for now assume he/she is falling into a supermassive black hole*

**What he/she sees next we can only speculate about (after all, no information ever escapes black holes!)**

# From the astronaut's perspective contd. (supermassive black hole)

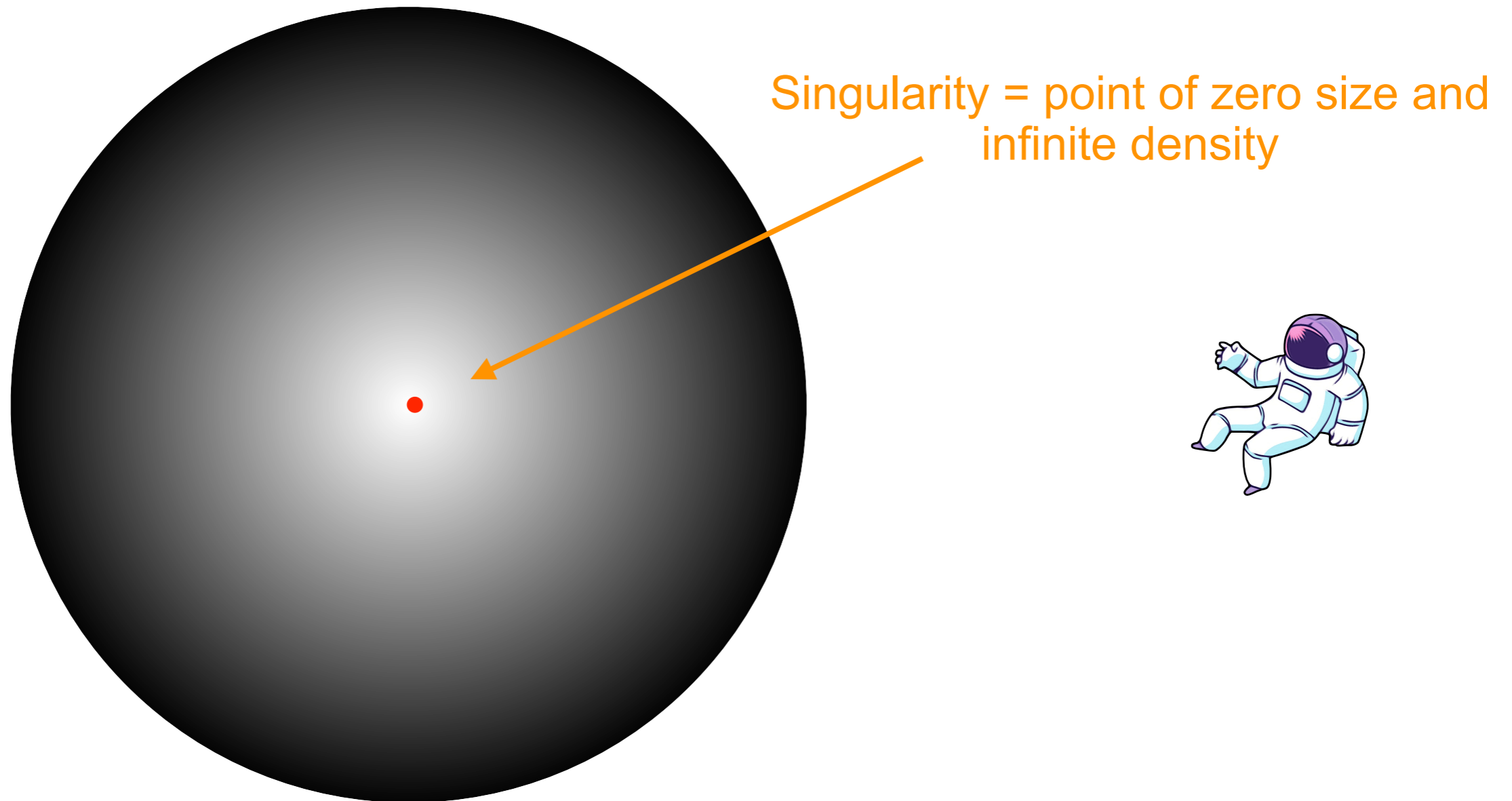

- Crosses event horizon normally
- At that point, may see \*entire history of the Universe\*
- Eventually gets crushed by the singularity

# From the astronaut's perspective contd. (supermassive black hole)

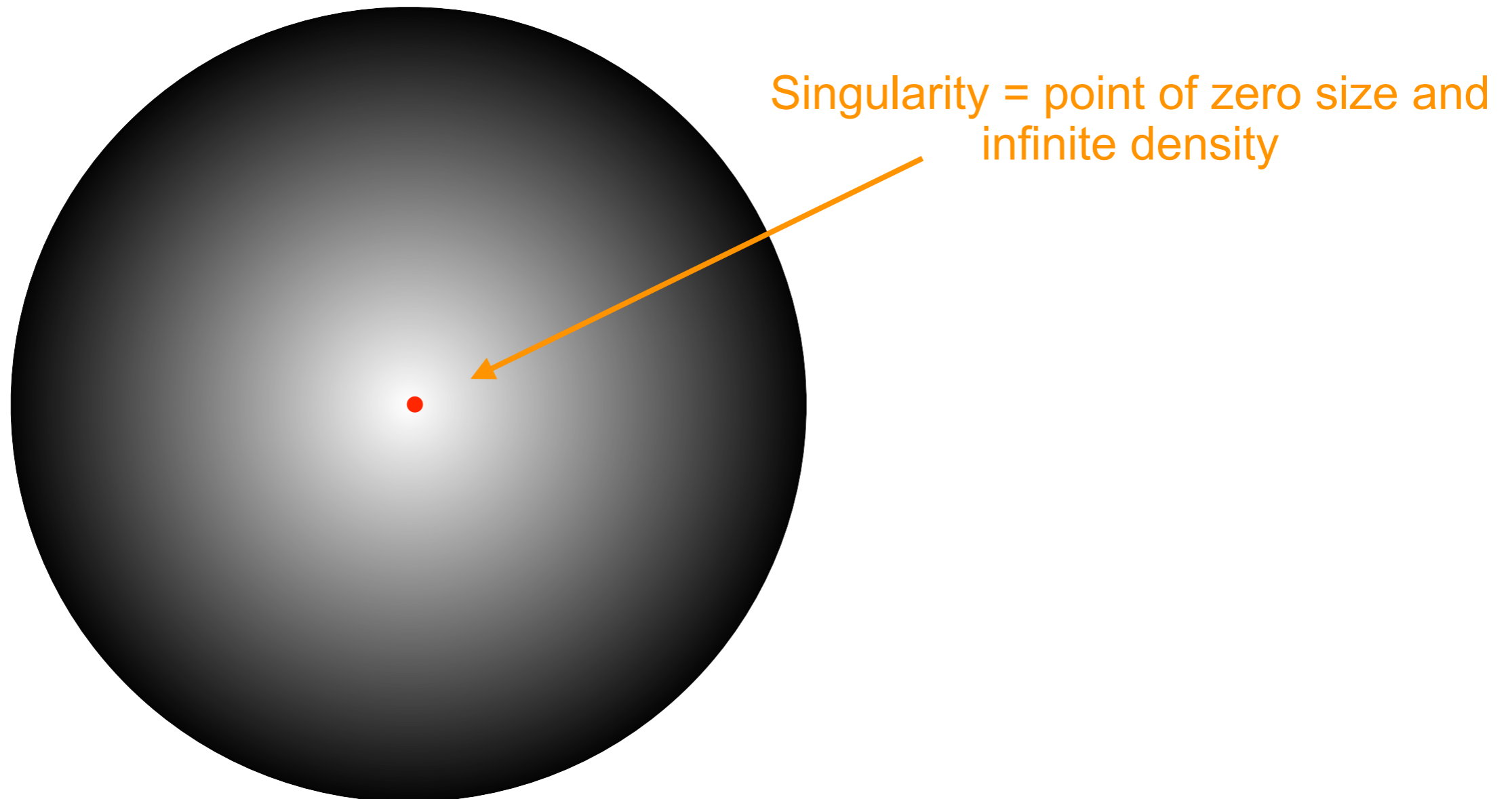

- Crosses event horizon normally
- At that point, may see \*entire history of the Universe\*
- Eventually gets crushed by the singularity



# A simulation of what it may look like to fall into a black hole



Andrew Hamilton

# A few more thoughts

- **But not clear if singularity actually exists**
- **Quantum mechanics deals with the physics of the VERY small**
- **Right now, quantum mechanics and GR do not mesh well**
- **More research needed!**

# Gravitational Waves

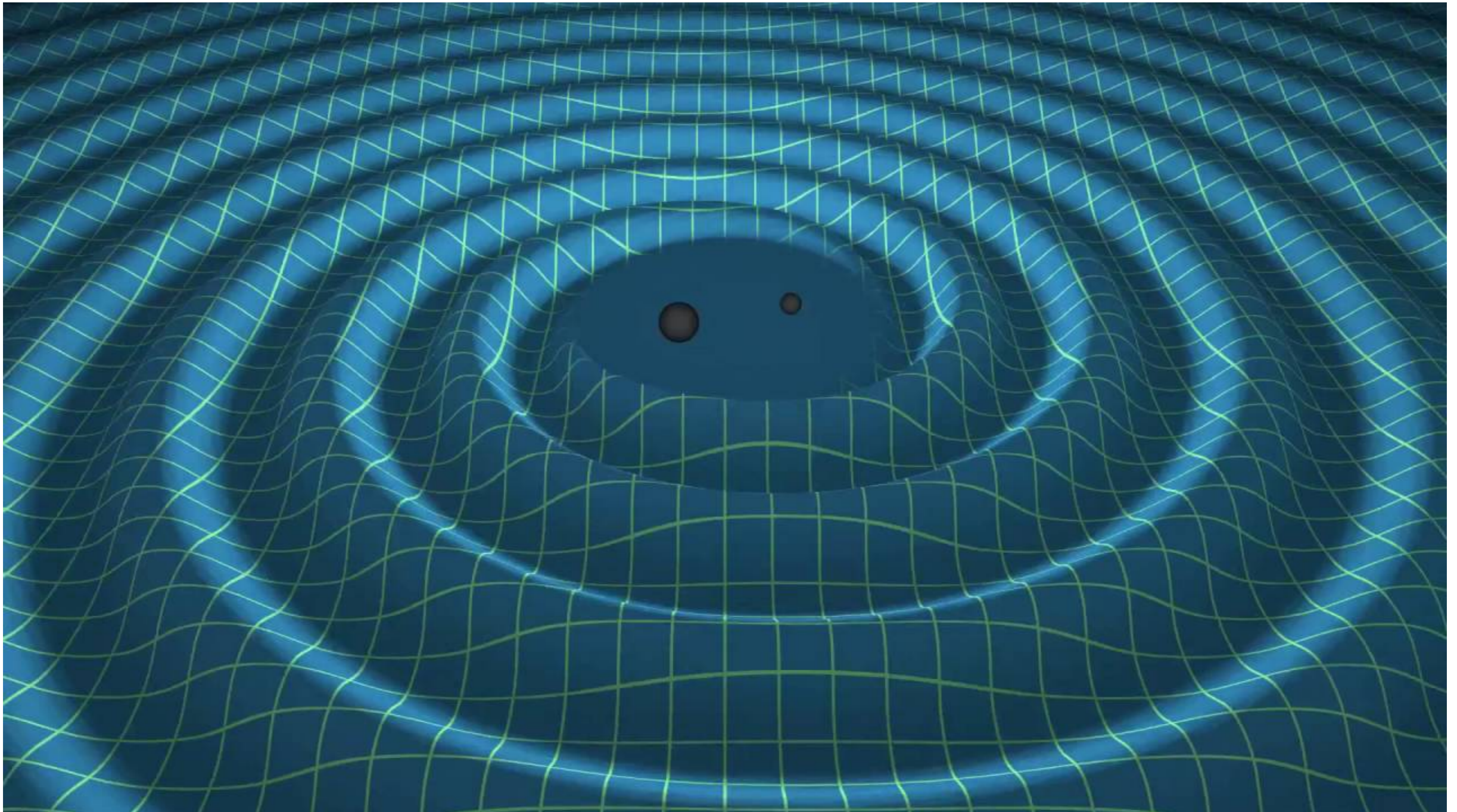

- **Binary black holes orbit each other.**
- **Gravitational waves are emitted, which remove angular momentum**
- **Eventually the black holes merge producing a burst of gravitational waves**

# Gravitational Waves

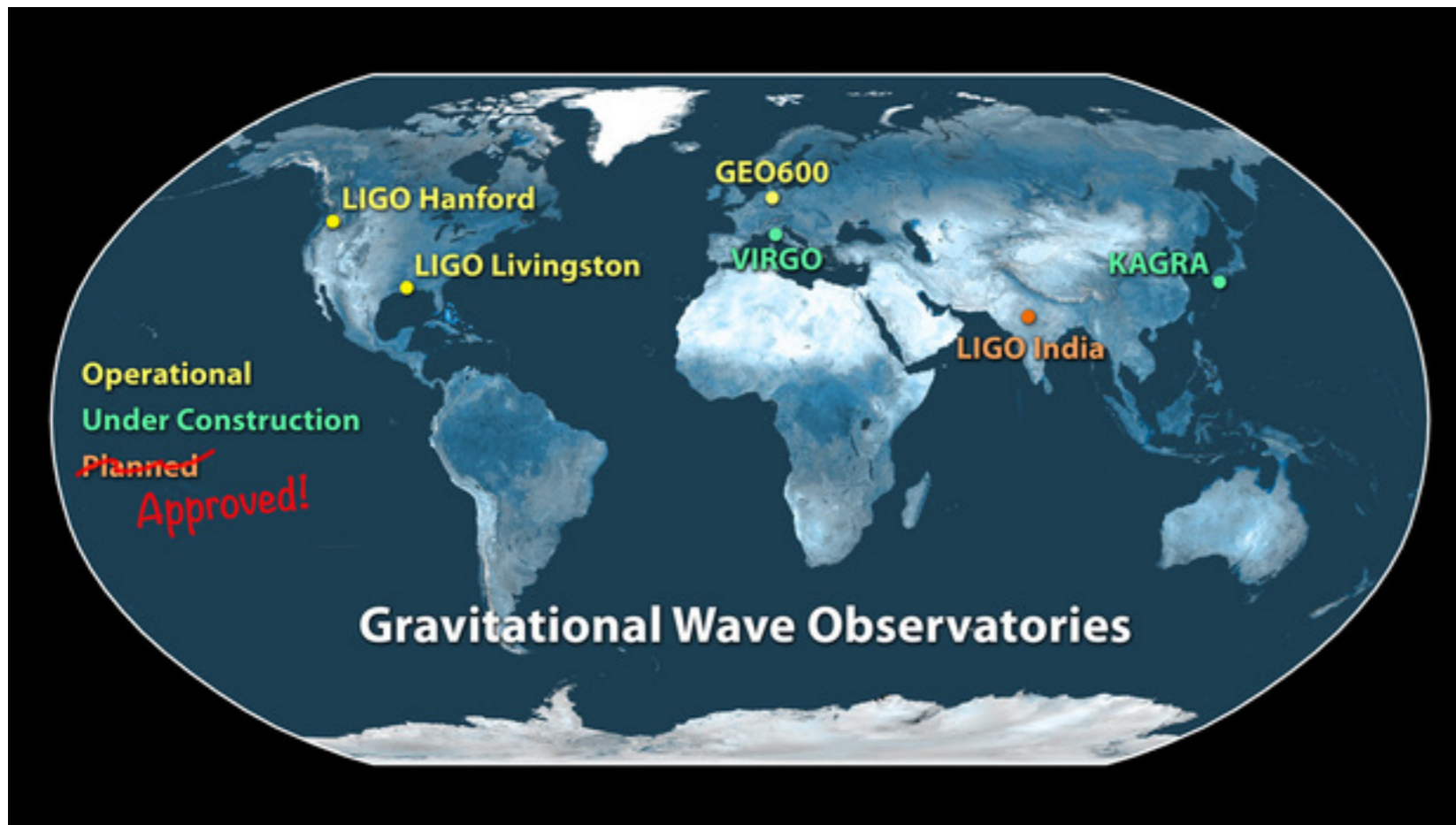

- Before LIGO (and other observatories), we relied almost exclusively on EM signatures
- Now, we have another source of information about the Universe, and it is already leading to unexpected discoveries

